

## DCA Weightmaster | DCA Megamaster | DCA Airmaster | DCA Steermaster 21 | DCA Railmaster | DCA Pavemaster

EN Guidelines for operation and maintenance



# 1 Explanation of symbols



## **WARNING!**

Means that death, serious bodily harm or significant material damage may result from non-compliance with the corresponding safety notes



## **ATTENTION!**

Means that minor injuries or material damage may result from non-compliance with the corresponding safety notes.



## **NOTE!**

Includes additional important information.



Environmental notes



Instruction



Continuation symbol



Page reference



Simplified tightening torque method



Tightening torque/angle tightening method



Tightening torque/angle loosen method



Safety-relevant threaded connection

## Table of contents

1	Explanation of symbols .....	2	19	Lift systems.....	47
2	Table of contents .....	3	19.1	Center lift DCA .....	47
3	Welcome to the world of JOST Achsen Systeme .....	4	19.2	Twin lift DCA.....	48
4	DCA Series: This is how you identify your axle!.....	4	19.3	Twin lift DCA “rocker” .....	49
5	Read prior to initial startup, repair and maintenance .....	6	20	Test and maintenance schedule for DCA trailer axles ....	50
6	Important safety information.....	7	21	Special tools for maintenance and repair.....	52
7	Observe during operation .....	13	22	Warranty .....	53
8	Identifying the axle .....	26	23	Technical information and data.....	54
9	Overview of repair and maintenance .....	27	23.1	Prescribed tightening processes .....	54
10	Axle housing .....	28	23.2	Tightening torque/angle tightening method.....	54
11	Suspension connection, front .....	29	23.3	Simplified tightening torque method .....	56
12	Suspension connection, rear .....	32	23.4	Tightening torque/angle loosen method.....	56
13	Wheel hub .....	34	23.5	Test procedure for threaded connections .....	57
14	Brake .....	38	24	Test and maintenance schedule for normal operation ...	58
15	Brake cylinder .....	41	25	Notice .....	62
16	DCA Steermaster 21 (steering axle).....	42	26	Service Contact .....	67
17	DCA Airmaster (axle with compressed air reservoir) .....	44			
18	Tyre inflation system (RFS).....	46			

### 3 Welcome to the world of JOST Achsen Systeme

Before you use the trailer, familiarize yourself with your JOST trailer axles. Read these guidelines, in particular the safety information and warnings before you start driving. By doing so, you will avoid hazards both to yourself and to others. JOST Achsen Systeme is constantly adapting trailer axles, components and parts so that they correspond to the latest state-of-the-art in science and technology and therefore reserves the right to modify shape, equipment and technology.

Always carry these documents along in the vehicle. Store a copy of this document in the trailer if the trailer is driven in alternating operation. Pass these documents along to the new owner when you sell the vehicle.

Have a safe trip!  
Your JOST Achsen Systeme, Service Department.

[www.jost-axle-systems.com](http://www.jost-axle-systems.com)

### 4 DCA Series: This is how you identify your axle!

DCA stands for Durable Compact Axle. A modular trailer axle system by the JOST Group. For individual solutions, precisely tailored to meet your needs.

#### **DCA Weightmaster, DCA Megamaster, DCA Pavemaster, DCA Railmaster**

The axle housing for these axle types is identical. The individual components have application-specific differences.

#### **Identifier "Model" on the identification plate**

D749324 D749325 D749334 D749349

With tyre inflation system: D749368 D749369

#### **DCA Airmaster**

This trailer axle stores compressed air in your axle housing for the air suspension and the brake system.

#### **Identifier "Model" on the identification plate**

D749360 D749361

#### **DCA Steermaster 21**

The steering axle with all of the advantages of the Durable Compact Axle: Low axle weight with a higher load-bearing capacity.

#### **Identifier "Model" on the identification plate**

D749310 D749311



## 5 Read prior to initial startup, repair and maintenance

This booklet serves as a guideline for operation and is designed for drivers and vehicle fleet operators (trailer users). Additionally, this booklet is intended as a guideline for repair and maintenance for qualified workshops personnel/qualified workshops.

This booklet is not intended for use as an instruction manual for the repair or maintenance of JOST Trailerachsen by drivers and vehicle fleet operators.

This booklet is not intended for use as an instruction manual for the installation or conversion of JOST Trailerachsen in the vehicle/ in vehicles as well as the removal from vehicles.

### **The following minimum requirements must be met in order to perform maintenance and repair work:**

- Qualified expert knowledge (qualified workshop personnel for commercial vehicles)
- Extensive experience with trailer axles for heavy commercial vehicles
- Professional commercial vehicle workshop equipment
- Access to all special tools required
- Access to sources of electronic workshop specialized information from JOST Achsen Systeme

### **Recommendation:**

Always have a qualified workshop carry out any maintenance and repair work

### **Recommendation to receive instructions**

JOST Achsen Systeme recommends that drivers be given instructions on the topic of axles before starting to drive for the first time. A person is considered instructed in the topic of axles, if he/she has at least ...

- Read all of the following instructions for drivers and vehicle fleet operators before starting to drive **and**
- Verifiably attended an instruction session (e. g. by the vehicle manufacturer or the vehicle fleet operator) on the topic “Loads” and “Permissible axle loads” **and**
- Has a valid driving license for these vehicles when starting to drive.

Drivers or vehicle fleet operators should read the following sections before starting to drive for the first time:

- **Important safety information** (▷ Page 7)
- **Observe during operation** (▷ Page 13)

### **Note for maintenance and repair**

Please observe the following additional information for maintenance and repair in addition to these guidelines:

- Menu item Service on the website  
[www.jost-axle-systems.com](http://www.jost-axle-systems.com)

Observe the notes in these guidelines regarding the proper operation of your axle system as well as possible vehicle damage.

## 6 Important safety information

Your JOST trailer axle systems were manufactured corresponding to the latest state-of-the-art in science and technology. Nonetheless, not all hazards to life and limb of the user or others can be ruled out due to the functional properties. Furthermore, the vehicle and other material assets can be damaged.

The following safety information will provide you with **precautionary information, so that you**

- Know major sources of hazards
  - Can prevent hazards and thus any resulting consequences from occurring
  - Can recognize hazards that arise as early as possible.
- ▶ Drivers should read and observe the following safety information before they drive with this vehicle for the first time. We recommend that you refresh your knowledge from time to time and to read this safety information repeatedly during the operation period.
- ▶ Vehicle fleet operators should read and observe the following safety information before starting to operate the vehicle.
- ▶ Please observe the general warnings and hazard warnings as well as the instructions on the other pages of this publication during operation.
- ▶ Please note that there can be additional hazards that are not known or that have never occurred before. This is why we ask you to act responsibly and with the adequate level of care!

### Overview of topics

- Intended use Page 8
- Misuse of the vehicle and consequences Page 8
- General warnings and hazard warnings Page 8
- Instructions Page 9
- Product modifications/structural changes Page 9
- Maintenance and repair work Page 9
- Welding on the axle system Page 9
- Threaded connections Page 9
- Ride height and ride height level control Page 10
- Suspension connection, suspension and damping Page 10
- Wheel end with wheel and wheel hub Page 11
- Brakes Page 11
- Axle with compressed air reservoir (DCA Airmaster) Page 11
- Axle with RFS preparation (tyre inflation system) Page 11
- Axle lifting Page 11
- Straightening work due to accident damage Page 12
- Replacement parts and components Page 12
- Accessories Page 12
- Your reaction can make a difference Page 12

## 6 Important safety information

### Intended use

Your vehicle with JOST trailer axles was built for a defined purpose and for defined operating conditions. Using it differently can pose a hazard to yourself and other road users.

- ▶ Please observe all trailer manufacturer specifications.
- ▶ Please observe the specifications in official vehicle documents (e. g. permissible axle load, permissible overall mass).
- ▶ Please observe all specifications in this booklet as well as the specifications on the operating conditions for axles (▶ Page 24).

### Misuse of the vehicle and consequences

If you do not observe specifications by the trailer manufacturer or axle manufacturer or the statutory specifications, you run substantial risks. You endanger your life and your safety as well as the life and the safety of others.

### General warnings and hazard warnings

General warnings and hazard warnings are marked with the  symbol as well as with the signal words WARNING or ATTENTION. General warnings and hazard warnings are provided for your safety, the safety of others and the safety of your vehicle. The notes contain specific instructions on how you prevent hazards from occurring altogether or in part. You can understand and potentially reduce the consequences of the hazard.

- ▶ Read and observe the general warnings and hazard warnings. Use it to protect yourself and others.
- ▶ Drivers should check prior to performing an activity, whether these guidelines contain general warnings and hazard warnings on this activity.
- ▶ Specialists from a qualified workshop should check prior to performing an activity, whether these guidelines contain general warnings and hazard warnings on this activity. Please also check whether the additional information contains general warnings and hazard warnings.

Please observe the additional information at:  
[www.jost-axle-systems.com](http://www.jost-axle-systems.com), menu item Service.



## 6 Important safety information

### Instructions

Instructions are marked with the ► symbol.

- Please read and observe the instructions before you carry out an activity. Carry out the activity as described in the respective instructions.

### Product modifications/ structural changes

Structural changes on the axle system will result in the immediate expiration of the operating permit and will negatively affect road safety.

- Please do not make any structural changes to the trailer axles.
- Please exclusively have the vehicle manufacturer make possible structural changes to the axle systems.
- Please have the vehicle manufacturer exclusively install high-quality replacement parts (e. g. JOST original parts).

### Maintenance and repair work

Improperly performed maintenance and repair work can pose a hazard to your life as well as to the life of other road users. Please exclusively have qualified workshops perform maintenance and repair work on the axle systems and the associated components.

### Welding on the axle housing

Welding can damage the axle housing or components and negatively affect road safety.

- Never perform any welding work on JOST trailer axles.
- Never have any welding work performed on JOST trailer axles. In case of doubt, contact your trailer manufacturer.

### Threaded connections

Please exclusively have qualified workshops loosen any threaded connections and create new ones.

Exception: If drivers must loosen wheel nuts and screw them on again in case of emergency (e. g. flat tyre), they need a torque wrench to reliably tighten wheel nuts (► Page 22). Have a qualified workshop check the wheel nuts as soon as possible.

Please observe the particularly safety-relevant threaded connections, which are marked with  in this booklet.

Tightening torque/angle tightening method: Threaded connections produced using the tightening torque/angle tightening method are marked with  in the booklet. The structure of the used fasteners is damaged after they have been loosened and therefore they compromise road safety. Dispose of all screws/ bolts, nuts and other fasteners used during this process after loosening the connection. When you create a new connection of this type, always employ the tightening torque/angle tightening method and always use new fasteners.

## 6 Important safety information

Simplified tightening torque method: Threaded connections produced using the simplified tightening torque method are marked with  in the booklet.

Tightening torque/angle loosen method: Threaded connections that were established with tightening torque/angle loosen method: are marked in the booklet with . If the used screws/bolts, nuts and other fasteners are OK from a technical standpoint based on the result of a visual inspection, you can reuse them (e. g. thread OK, no corrosion).

All torque values specified by JOST Achsen Systeme apply exclusively to JOST original replacement parts. JOST Achsen Systeme cannot assess replacement parts from external sources. JOST Achsen Systeme does not know the torque values permissible or required for replacement parts from external sources. Significant deviations are possible. Faulty threaded connections or those with inadequate load ratings pose a potential accident hazard. Please contact your trailer manufacturer directly if you have any questions regarding replacement parts from external sources.

- ▶ Before you start any work, observe the “Technical information and data” section (▶ Page 54).
- ▶ Please observe the trailer manufacturer specifications.
- ▶ Please exclusively use high-quality replacement parts (e. g. JOST original replacement parts).

### Ride height and ride height level control

The ride heights of tractor and trailer must be coordinated with each other.

- ▶ Please observe the trailer manufacturer specifications.
- ▶ There is a danger of crushing during lowering/lifting. Keep a safe distance from all moving parts.
- ▶ Make sure before starting to drive that tractor and trailer are at the proper “driving level”.
- ▶ Observe the warning indications in the instrument cluster of your tractor. Observe any acoustic warnings.

### Suspension connection, suspension and damping

Damper, air bellows, 3D bushings and wear plates are put under severe strain due to their function. The more demanding the operating conditions, the higher the wear. Severe or complete wear leads to an increased accident hazard and can damage the axle system completely.

- ▶ Observe the handling characteristics of the trailer. If you notice any unstable handling characteristics or a loose nut/screw connection, contact a qualified workshop before driving/continuing to drive and ask for instructions.
- ▶ Have test and maintenance work performed in due time by a qualified workshop in accordance with the test and maintenance schedule.

## 6 Important safety information

### Wheel end with wheel and wheel hub

Damage, wear and corrosion on tyre, rim, wheel hub, wheel stud or wheel nuts can negatively affect the vehicle's road safety. There is a risk of accident.

- ▶ Observe the condition and the wear on these parts.
- ▶ Have test and maintenance work performed in due time by a qualified workshop in accordance with the test and maintenance schedule.

### Brakes

Friction is generated during braking. Friction causes heat. The brake system, in particular brake disc, brake caliper, wheel hub and rim can become so hot during operation that there is a risk of burn injuries.

- ▶ Keep an adequate safe distance from heated up components of the axle system.
- ▶ Never touch heated up components with bare hands or other body parts.

In the event of wear/faults/malfunctions on the brake system, brake power decreases, becomes irregular or fails completely. There is a risk of accident.

- ▶ Have test and maintenance work performed by a qualified workshop in accordance with the test and maintenance schedule.

### Axle with compressed air reservoir (DCA Airmaster)

Axles with compressed air reservoir (DCA Airmaster) are under high pressure. There is a risk of injury.

- ▶ Please observe the notes on draining the axle housings before starting to drive (▶ Page 16).
- ▶ Please observe the notes on working on axles with compressed air reservoir (▶ Page 44).

### Axle with RFS preparation (tyre inflation system)

If an optional RFS preparation is present: Axles with RFS preparation are under high pressure. There is a risk of injury. You can identify the RFS preparation by an information label on the axle housing.

- ▶ Never use the compressed air connections of the RFS preparation for other purposes (e.g. brake system, air suspension system, other compressed air-operated equipment).
- ▶ Please observe the notes on axle with RFS preparation (▶ Page 46).
- ▶ Please observe the instructions and maintenance procedures of the RFS system provider/trailer manufacturer.

### Axle lifting

There is a danger of crushing when you lift/lower an axle.

- ▶ Keep a safe distance to the axles during lowering/lifting.

## 6 Important safety information

### **Straightening work due to accident damage**

Straightening work on JOST trailer axles negatively affects road safety.

- ▶ Drivers or vehicle fleet operators should never perform any straightening work on an axle. Never exchange an axle.
- ▶ Always have a qualified workshop exchange the axle

### **Replacement parts and components**

JOST trailer axles are based on high-quality components. This is the foundation for high road safety. Faulty replacement parts or threaded connections or those with inadequate load ratings increase the risk of accident.

- ▶ Recommendation: Use JOST original replacement parts. JOST Achsen Systeme can't assess replacement parts from external sources. JOST Achsen Systeme does not know the torque values permissible or required for replacement parts from external sources and permissible load limits. Significant deviations from JOST original replacement parts are possible. If you don't know the permissible or required tightening processes and torque values as well as the permissible load limits, you run high risks for life and limb.
- ▶ Always have a qualified workshop order replacement parts and perform repair work.

### **Accessories**

Improper accessories can compromise the road safety of the vehicle (e. g. non-approved tyres, rims, wheel hub covers). There is a risk of accident.

- ▶ Please observe the vehicle manufacturer's recommendation/ list of approved components.

### **Your reaction can make a difference**

Even if you observe all specifications, all general warnings and hazard warnings as well as all safety information, there can be residual risks. This is why your reaction can make a difference.

- ▶ Remember when driving and when working on the vehicle, that technology and safety systems are subject to physical limits.
- ▶ Please be careful and act responsibly. Please be considerate towards others.

## 7 Observe during operation



### WARNING!

There is a risk of accident when working on the vehicle. If you do not observe the following measures, you endanger your life and the life of other road users. Pay attention to traffic and take precautions. Before you start with tests or work on the vehicle: Secure your vehicle with the parking brake and with wheel chocks to prevent it from rolling off inadvertently. Always wear a safety vest and suitable protective/safety clothing while performing work/inspections/tests on the vehicle and under the vehicle.



### WARNING!

Vehicles with safety defects endanger your life and the life of other road users. Never use any vehicles in road traffic if these vehicles have defective or damaged safety-relevant parts. In case of doubt: Do not drive the vehicle!

### Always keep the guidelines at hand

- ▶ Always carry these documents along in the vehicle.
- ▶ Store a copy of this document in the trailer if the trailer is driven in alternating operation.



### NOTE!

These guidelines in the most recent version can be found on the website at [www.jost-axle-systems.com](http://www.jost-axle-systems.com) under the menu item Service.

### Observe the manufacturer instructions

- ▶ Observe the specifications/the instructions of the trailer manufacturer. If you have questions about the trailer or if you are unsure, please contact your trailer manufacturer.
- ▶ When dealing with trailer axles, please also observe specifications/the instructions on JOST trailer axles in these guidelines. If you have questions about your JOST trailer axles, please contact the Service Hotline at JOST Achsen Systeme ([www.jost-axle-systems.com](http://www.jost-axle-systems.com), menu item contact).

### Departure check routine

- ▶ Prior to each trip, perform a proper departure check routine.
- ▶ While doing so, please observe the operating instructions/directions of the tractor and trailer manufacturers.
- ▶ Additionally, please observe the following instructions regarding tests on the vehicle and on the axle system.
- ▶ Prevent consequential damage. Make sure that
  - Tractor and trailer fit together (brake matching of tractor/trailer combination, driving level)
  - Chassis, suspension, brake system or wheels of the trailer do not show any externally visible signs of damage (e.g. from an accident, damage to property, manipulation)
  - Your ride height regulation is set to “driving level”

## 7 Observe during operation

- The electrical connectors are suitable for the trailer, correctly plugged in and not damaged
- The compressed air connections are suitable for the trailer and correctly connected
- Statutory inspection deadlines have not been exceeded
- The permissible gross vehicle weight as well as the permissible axle load have not been exceeded
- Wheels/tyres are suitable for this trailer based on the information of the trailer manufacturer and are in proper condition (adequate profile, tyres not damaged, correct tyre pressure)
- Wheel nuts are not loose or missing (simple visual inspection without tools)
- Wheel nuts and wheel studs are not damaged
- Other threaded connections are not loose or missing (simple visual inspection without tools)
- Wheels are not at an unusual incline (e. g. by looking along the side of vehicle from the end of the vehicle). Wheels must be virtually vertical.
- No leaking grease is visible from the outside at the wheel hub
- Air bellows are not damaged and, on the special version with separated air bellows piston (piggyback), they are threaded correctly.
- You do not notice any unusual noises caused by escaping compressed air while the engine is running and with proper compressed

If one or several of the problems above occurs:

- ▶ Contact the vehicle fleet management and a qualified workshop before driving/continuing to drive. Ask them for further instructions.

### Tests during the trip

---



#### **WARNING!**

Visual warning signals or chimes, extraordinary driving noise, uneven or reduced brake power, unstable handling characteristics of the trailer or the complete tractor/trailer combination, unusual wheel position, smoke development or loose parts can be an indicator for imminent or already existing damage to the trailer. There is a risk of accident. Interrupt your trip. Contact a qualified workshop before continuing to drive and ask for instructions.

---

Limit damage and their consequences by detecting them early on. You can detect an imminent or already existing damage to the trailer while driving e. g. by

- Warning indications in the instrument cluster
- Chimes
- Extraordinary driving noise (e. g. indication of defects on the wheel hub or the suspension connection or of loose parts)
- Uneven or reduced brake power (e. g. indication of wear or defects on the brake system)

## 7 Observe during operation

- Unstable handling characteristics of the trailer or the complete tractor/trailer combination (e. g. indication of defects on the wheel).
- Regularly looking into the rearview mirror (unusual wheel position, smoke development, loose parts).

If one or several of the problems above occurs:

- ▶ Interrupt your trip.
- ▶ Please observe the notes of the trailer manufacturer as well as the notes in these guidelines.
- ▶ Contact the vehicle fleet management and a qualified workshop before continuing to drive. Ask them for further instructions.

### Tests while the trip is interrupted and at the end of the trip



#### **WARNING!**

Tyres, rims, wheel hub, brakes and other components can become very hot during driving operation. When you touch heated up vehicle parts directly with hands or other body parts, there is a risk of burn injuries. This is why you should wear suitable protective/safety clothing when working on the vehicle. Keep an adequate safe distance.



#### **WARNING!**

Strongly heated rims/wheel hubs or strongly and unevenly heated rims/wheel hubs or excessive grease leakage can be an indication for imminent bearing damage. Bearing damage can lead to a loss of wheels. Overheated brakes can lead to a loss of the braking effect, to wheel end damage down to a broken axle. There is a risk of accident. Before you continue to drive: Ask a qualified workshop for further instructions.

- ▶ The rim/wheel hub can be very hot. Do not touch hot rims/wheel hubs directly with bare hands. Keep a safe distance.
- ▶ From a safe distance of a few centimeters, check for each wheel whether your rims/wheel hubs have become unusually hot or have heated up unevenly.

If one rim/wheel hub is unusually hot or if your rims/wheel hubs have noticeably heated up unevenly:

- ▶ Contact the vehicle fleet management and a qualified workshop before driving/continuing to drive. Ask them for further instructions.

## 7 Observe during operation

### Draining the axle housing before starting to drive

(only for the axle system with compressed air reservoir/energy reservoir/DCA Airmaster with the identifier "Type des." D749360 or D749361 on the identification plate)



#### **WARNING!**

This axle housing is also used as a compressed air reservoir for the air spring and brake system. The axle housing is therefore directly connected to the compressed air supply of the trailer. If the supplied compressed air contains moisture, this moisture can collect in the axle housing. As a result, the brake pressure air supply can decrease. The brake system can fail partially or completely. There is a risk of accident and death for you and other road users. For safety reasons, drain the axle before starting to drive (once a day). If moisture is coming out while draining the axle, this can be an indication for poor air dehumidification in the compressed air system of the tractor.

---



#### **WARNING!**

The axle housing is under pressure. In particular on the axle system with compressed air reservoir (DCA Airmaster), welding can cause irreparable damage to the internal coating of the system. Operational safety is no longer ensured in this case. Improperly performed work on the axle housing can pose a hazard to your life and the life of others. There is a risk of accident. Please exclusively have a qualified workshop perform assembly work on the axle housing. Do not perform any welding on the axle housing. Do not have any welding performed on the axle housing. In case of doubt, contact the trailer manufacturer.

---



#### **WARNING!**

The axle housing is under pressure. There is a risk of accident and injury. Protect yourself when draining the axle. Wear a safety vest and suitable protective/safety clothing. Be especially carefully when moving under the vehicle. Pay special attention to obstacles and edges to protect yourself from injury. Keep a safe distance of approximately one arm's length between your head and the axle during draining.

---



## 7 Observe during operation

Axles with compressed air reservoir must be drained before starting to drive (once a day).

- ▶ Secure the standing vehicle with the parking brake before starting to work. Additionally, secure the vehicle properly with wheel chocks to prevent it from rolling off inadvertently.
- ▶ Familiarize yourself with the position of the drain valves.
- ▶ Remember that compressed air will flow out when the drain valve is opened. This is why you should keep a distance from the drain valve. Work with the arm extended.

- ▶ Carefully pull on the ring of the drain valve until you feel the end stop.
- ▶ If you do not see any water coming out and only compressed air escapes, you can let go of the ring again. The valve closes automatically.
- ▶ If you see water coming out, let the water flow out completely. If there is no more water coming out and only compressed air escapes, you can let go of the ring again. The valve closes automatically.

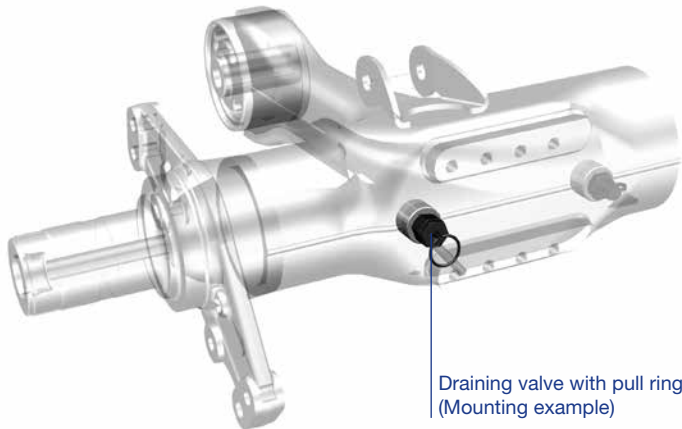

Draining valve with pull ring  
(Mounting example)



### NOTE!

Typically, little or no moisture is escaping. If moisture escapes regularly: Have air drier of tractor checked/repaired in the qualified workshop. If moisture continues to escape: Have entire compressed air system as well as axles checked in a qualified workshop.

---

## 7 Observe during operation

### Brake system

The following information on the topic of brakes relates to the disc brakes by Knorr-Bremse in model series SN6 TDB 0874, SN7 TDB 0876, SK7 TDB 0875, DCA-T7 TDB 0883 and Haldex disc brake in model series DCA-L7 TDB 0877.



#### **WARNING!**

Poor or irregular maintenance as well as improperly performed work on the brake system negatively affect the functional capability of the entire brake system. The entire brake system can fail. There is a risk of accident. Please make sure that test and maintenance work is performed and observe the maintenance intervals as per the test and maintenance schedule. Always have a qualified workshop perform any maintenance and assembly work on the brake system. After any maintenance or assembly work, check the brake function and the system behavior before starting to operate the vehicle.



#### **WARNING!**

Strongly heated rims/wheel hubs or strongly and unevenly heated rims/wheel hubs or excessive grease leakage can be an indication for imminent bearing damage. Bearing damage can lead to a loss of wheels. Overheated brakes can lead to a loss of the braking effect, to wheel end damage down to a broken axle. There is a risk of accident. Before you

continue to drive: Ask a qualified workshop for further instructions.



#### **WARNING!**

The brake system is under pressure. High forces are acting on the components of the brake system. There is a risk of accident and injury. There is the risk of death if work on the brake system is not performed properly. Exclusively have a qualified workshop perform any maintenance and assembly work on the brake system. Keep a safe distance, in particular to the moving parts of the brake system.



#### **WARNING!**

There is a risk of accident during the visual inspection on the brake system if the vehicle is not secured as well as possible from traffic. Pay attention to traffic and take precautions. Wear a safety vest and suitable protective/safety clothing. Before you start with tests on the brake system: Apply the parking brake and carefully secure the vehicle with several wheel chocks to prevent it from rolling off inadvertently. After the test, remove the wheel chocks only while the parking brake is applied.

## 7 Observe during operation

### Manually releasing the spring brake in an emergency or in the workshop

Typically, you can release the spring-loaded parking brake pneumatically. Please observe the trailer manufacturer specifications on this.

A qualified workshop can manually release the spring-loaded parking brake in an emergency if there is no reservoir pressure.

- ▶ Contact a qualified workshop and ask for the mobile service or ask them for further instructions.

### Brake pads and brake discs



#### **WARNING!**

If the brake pads are too worn, the braking effect is reduced or the brake fails completely. There is a risk of accident. For your own safety, please make sure that your brake pads are within the permissible wear limits. Have a qualified workshop check the brake lining thickness in regular intervals in accordance with the test and maintenance schedule, however, at least every 3 months. For safety reasons, check the brake wear once a week with the wheels installed. Please observe the following instructions on how to do this.



#### **WARNING!**

If the brake discs are too worn, the braking effect is reduced or the brake fails completely. There is a risk of accident. For your own safety, please make sure that your brake discs are within the permissible wear limits. Have a qualified workshop check the brake discs in regular intervals in accordance with the test and maintenance schedule. Additionally, have the brake discs checked whenever the brake linings are replaced.

### Check wear with the wheels installed

For rough orientation, you can check the wear of brake lining and brake disc from time to time with the wheels and the brake installed.



#### **WARNING!**

If the brake pads/brake linings are too worn, the braking effect is reduced or the brake fails completely. There is a risk of accident. The quick wear test of brake lining and brake disc with the wheels installed is only used to provide a rough orientation. In no case is this method a substitute for the test and maintenance intervals in accordance with the test and maintenance schedule in a qualified workshop.

## 7 Observe during operation

### Quick wear test for Knorr brakes SN6/SN7/SK7/DCA-T7

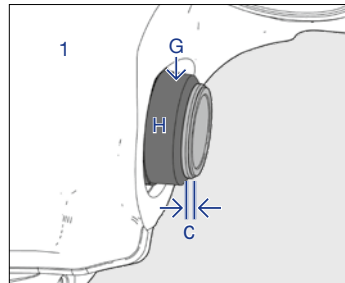
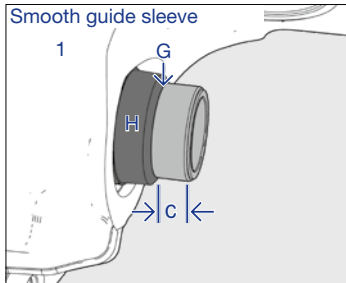
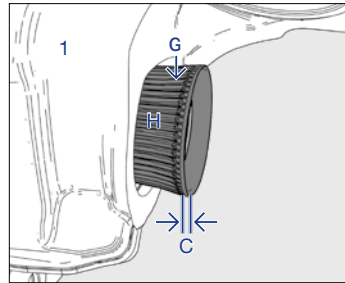
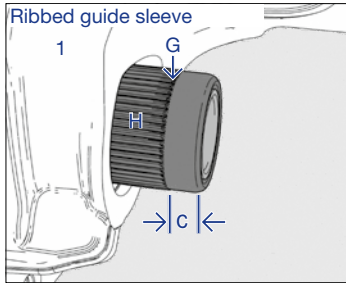

Dimension C for new linings and a new brake disc

1 = Brake caliper  
H = Guide sleeve  
G = Test point  
C = Test dimension

Dimension C for worn linings and a worn brake disc. Brake lining and brake disc test imperative with the wheels removed.

In radial disc brakes with a ribbed or smooth guide sleeve (H), test dimension C must be  $> 1$  mm.

If C is  $\leq 1$  mm, have a qualified workshop check brake linings and brake disc with the wheels removed as soon as possible.

**Please note:** Always have all the brake pads on the same axle replaced at the same time.

In disc brakes with caliper and carrier marking (brake caliper marking P and brake carrier marking R), pay attention to the position of the P and R markings relative to each other. If P and R are nearly on top of each other, have a qualified workshop check brake linings and brake disc with the wheels removed.

**Please note:** Always have all the brake pads on the same axle replaced at the same time.

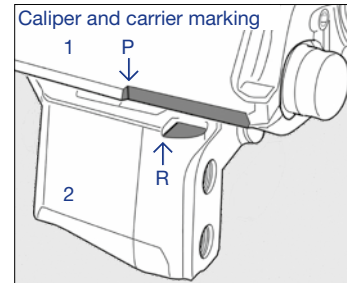

Position P and R for new linings and new brake disc

1 = Brake caliper  
2 = Brake carrier  
R = Test point

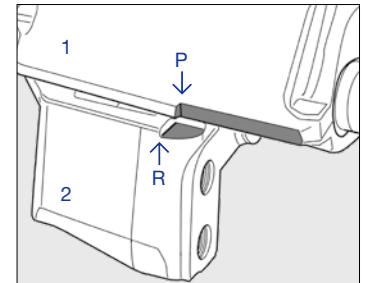

Position P and R for worn linings and worn brake disc. Brake lining and brake disc test imperative with the wheels removed.

## 7 Observe during operation

### Quick wear test for DCA-L7 brakes

- Inspect the position of the visual pad wear indicator.

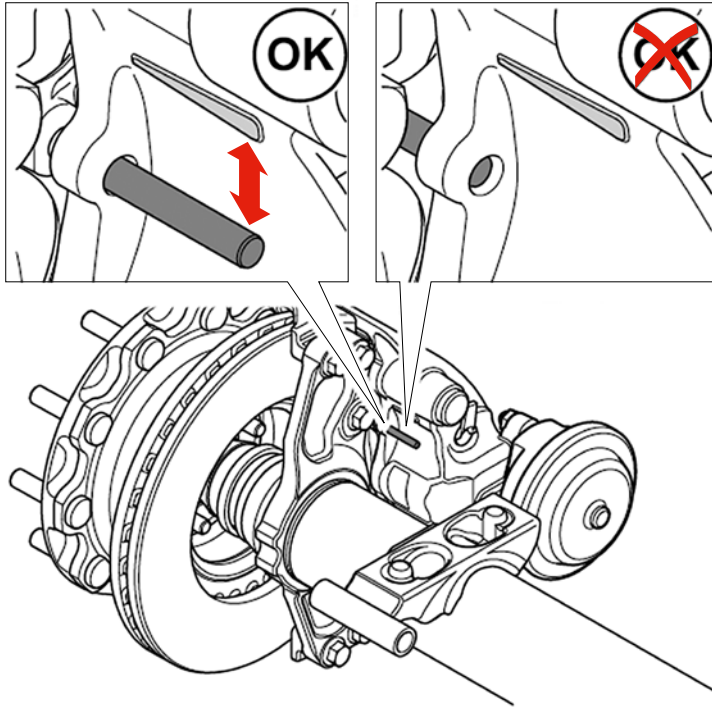

### Sensor for indication of brake pad wear

If an electronic wear indicator was installed in your trailer: This indicator can let a warning light come on in your instrument cluster when the brake linings/brake discs are too worn (or you hear an acoustic warning). In no case is this type of wear indicator a substitute for the specified regular tests in accordance with the test and maintenance schedule.

- Please observe the trailer manufacturer information on this.
- Check when you take over the trailer whether this type of electronic wear indicator was installed. If it is not available: A warning lamp will not come on/you will not hear an acoustic warning when the brake linings/brake discs are too worn.

## 7 Observe during operation

### Tractor/trailer combination brake matching

Tractor/trailer combination brake matching helps to appropriately distribute braking work to all brakes/axles in the tractor/trailer combination.

If your tractor vehicle is not EBS-controlled:

- ▶ Have a tractor/trailer combination brake matching performed within the first 5,000 km after the initial startup of the vehicle.

In EBS-controlled tractor vehicles, conventional tractor/trailer combination matching is typically not possible. If you use an EBS-controlled tractor vehicle:

- ▶ Have someone check whether the braking characteristics of your trailer are within the specified EC band,
  - If you notice particularly severe or uneven wear of the brake pads on the trailer brakes
  - If individual axles tend to lock during braking
  - If your trailer tends to push.
- ▶ If the braking characteristics of your trailer are within the specified EC band: Have someone check whether the braking characteristics of your tractor vehicle is within the EC band.
- ▶ If necessary, have the EBS parameters adapted in order to improve the distribution of the braking work to all brakes/axles of the complete tractor/trailer combination. Recommendation: Avoid a positive-tolerance calibration of the tractor for your JOST trailer axle systems.

### Wheel replacement



#### **WARNING!**

Jacking up using the in-car vehicle jack leads to a high point load at the respective axle housing. If the vehicle is not properly loaded or if you do not use the specified jacking point for the vehicle jack, the axle system can be damaged. The vehicle jack can give in. The vehicle can drop. There is a risk of accident and injury. Ask the mobile workshop service to perform the wheel replacement. Have the vehicle jacked up with professional jacking tools. If you have to jack it up yourself in an emergency: Please observe the specified jacking points for the vehicle jack. To do this, use a vehicle jack suitable for heavy commercial vehicles. Jack up the vehicle exclusively on one side. Do not work under the vehicle.

---

- ▶ Have your wheel replacements performed at a qualified workshop or by the mobile service of the workshop.

If you experience an emergency and have to replace a wheel without the help of a qualified workshop, you will need a torque wrench.

## 7 Observe during operation

If a torque wrench is not available:

- ▶ Contact the vehicle fleet management and a qualified workshop before replacing the wheel. Ask them for further instructions.

During an emergency wheel replacement, please do the following:

- ▶ Wear a safety vest and suitable protective/safety clothing. Secure any traffic.
- ▶ Secure the standing vehicle with the parking brake before starting to work. Additionally, properly secure the vehicle with several wheel chocks on the other side of vehicle to prevent it from rolling off inadvertently.
- ▶ Before you jack up the vehicle, observe the specifications of the vehicle manufacturer. Also observe the permissible jacking points for the vehicle jack shown in the illustration below.

For jacking up **on one side**: Position vehicle jack at point **A1** or **A2** marked in blue, but not on a weld seam.

For jacking up **on both sides**: Position vehicle jack at both blue areas **B1** and **B2**, but not on a weld seam.

- ▶ Jack up the vehicle using a vehicle jack suitable for heavy commercial vehicles.
- ▶ Loosen the wheel nuts. Pay attention to any remaining tension between wheel and wheel stud. Carefully pull off the defective wheel.
- ▶ Clean wheel hub, wheel studs, wheel nuts and the spare wheel. The contact surface of wheel hub, wheel studs, wheel nuts, wheel nut thread and rim must be free of paint/lacquer, corrosion and dirt.

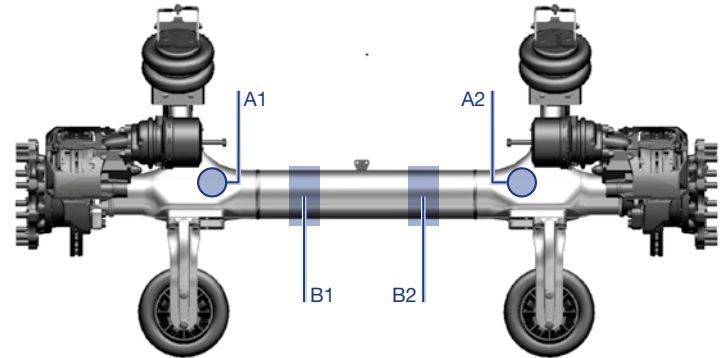

- ▶ Carefully slide the spare wheel onto the wheel studs.
- ▶ Tighten the wheel nuts (M22 x 1.5) with a torque wrench crosswise. Tightening torque: 600 Nm.
- ▶ Slowly lower the vehicle in a controlled manner.
- ▶ Properly stow and secure your defective wheel.
- ▶ Immediately check the tyre inflation pressure of the newly installed wheel.
- ▶ Tighten the wheel nuts crosswise after driving for 50 km. Tightening torque: 600 Nm.
- ▶ Have a qualified workshop check the wheel installation as soon as possible.

## 7 Observe during operation

### Unstable handling characteristics

---



#### **WARNING!**

Unstable handling characteristics of the trailer or the complete tractor/trailer combination can indicate an imminent or already existing damage to the suspension/to the suspension connection of the trailer. There is a risk of accident. Interrupt your trip. Contact a qualified workshop before continuing to drive and ask for instructions.

---

### Test and maintenance work

Observe the specified test and maintenance work and deadlines (▷ Page 50). Have all required work performed at a qualified workshop in accordance with the test and maintenance schedule (e. g. at a JOST Achsen Systeme service partner).

### Operating conditions in normal operation

The vehicle manufacturer defines the application purpose and the permissible operating conditions of your trailer. Please observe the trailer manufacturer specifications. Unless defined otherwise by the trailer manufacturer, operation on asphalt/concrete roads is considered normal operation.



## 7 Observe during operation

### Environmental protection

---



#### **ENVIRONMENTAL INFORMATION!**

JOST Achsen Systeme is committed to comprehensive environmental protection.

Objectives are frugal use of resources and sustainable management of the natural basis of existence that serves the preservation of humans and nature. By operating your vehicle in an environmentally friendly way, you too can make a contribution to environmental protection.

The wear of your DCA trailer axles as well as the brake and other axle components depends on the following factors:

- Operating conditions of your vehicle.
- Your personal driving style.

You can influence both factors. Therefore, please observe the following notes:

- Make sure that the tyre inflation pressure is correct.
- Observe the test and maintenance intervals.
- Always have a qualified workshop perform any service work.
- Drive with foresight and keep an adequate distance.
- Adjust your driving behavior appropriately if the road conditions are difficult (e. g. rough terrain, rough road surface test track, unsurfaced road).

---

## 8 Identifying the axle

Identify your axle and important components with the data on the identification plate. **You can find the identification plate on the centre of the axle housing.** This data will help you:

- To identify spare parts with the Part Finder: [jost-part-finder.com](http://jost-part-finder.com)
- Purchasing replacement parts
- Searching on the [www.jost-axle-systems.com](http://www.jost-axle-systems.com) website under the menu item Service
- When calling the Service Hotline of JOST Achsen Systeme: [www.jost-axle-systems.com](http://www.jost-axle-systems.com), menu item Contact

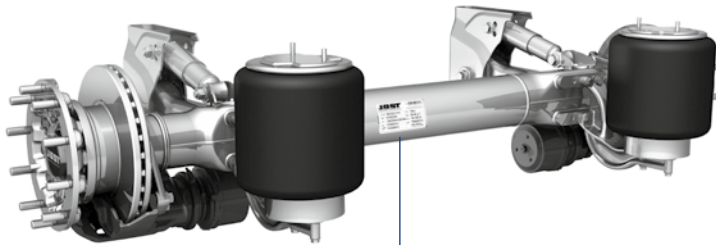

### Classification of the identification plate

<b>1</b>	<b>TZ</b> = Rigid axle, offset 0 <b>TE</b> = Rigid axle, offset 120 <b>TL</b> = Steering axle, offset 120
<b>2</b>	<b>8</b> = Series DCA
<b>3</b>	<b>D749324</b> } DCA WEIGHTMASTER, <b>D749325</b> } DCA MEGAMASTER, <b>D749334</b> } DCA PAVEMASTER, <b>D749349</b> } DCA RAILMASTER  <b>D749368</b> } Version with tyre inflation system <b>D749369</b> }  <b>D749360</b> } DCA AIRMASTER <b>D749361</b> }  <b>D749310</b> } DCA STEERMASTER 21 <b>D749311</b> }
<b>4</b>	<b>TDB 0876</b> = Brake SN7-22.5" <b>TDB 0874</b> = Brake SN6-19.5" <b>TDB 0875</b> = Brake SK7-22.5" <b>TDB 0877</b> = Brake DCA-L7-22.5" <b>TDB 0883</b> = Brake DCA-T7-22.5"

## 8 Identifying the axle



### NOTE!

Transfer the serial no./axle numbers (SN) 5 from the identification plates of your axles into this table

5 Serial no./axle numbers (SN):

Axle 1

--	--	--	--	--	--	--	--	--	--	--	--	--	--	--	--	--	--	--	--

Axle 2

--	--	--	--	--	--	--	--	--	--	--	--	--	--	--	--	--	--	--	--

Axle 3

--	--	--	--	--	--	--	--	--	--	--	--	--	--	--	--	--	--	--	--

## 9 Overview of repair and maintenance

**Recommendation:** Always have a qualified workshop carry out any replacement part research and replacement part ordering. Observe the minimum requirements for the safe performance of maintenance and repair work (▶ Page 6).

This chapter includes an excerpt from the repair instructions and maintenance notes regarding the DCA axle series.

▶ Please refer to the complete repair description on our website under [www.jost-axle-systems.com](http://www.jost-axle-systems.com), menu item Service.

### Repair instructions and maintenance notes for qualified workshops:

- ▶ Observe the test and maintenance plan in the following section.
- ▶ Alternatively you will find the test and maintenance plan on the website [www.jost-axle-systems.com](http://www.jost-axle-systems.com), menu item Service.
- ▶ If you have any questions, please contact the service hotline at JOST Achsen Systeme: [www.jost-axle-systems.com](http://www.jost-axle-systems.com), menu item Contact.

## 10 Axle housing

### Damaged axles



#### **WARNING!**

Straightening work on the axle housing negatively affects road safety. There is a risk of accident and therefore danger to life and limb. Always have a qualified workshop replace damaged axle housings in coordination with JOST Achsen Systeme.

### Service-Hotline

Contact persons for workshops: Service Hotline at JOST Achsen Systeme: [www.jost-axle-systems.com](http://www.jost-axle-systems.com), menu item Contact

### Complete information on the Internet

- Observe the complete repair description at [www.jost-axle-systems.com](http://www.jost-axle-systems.com), menu item Service.

### No welding



#### **WARNING!**

Welding on the axle system can damage the axle housing or components. In particular on the axle system with compressed air reservoir (DCA Airmaster), welding can cause irreparable damage to the internal coating of the system. Operational safety is no longer ensured in this case. Improperly performed work on the axle housing can pose a hazard to your life and the life of others. There is a risk of accident. Please exclusively have a qualified workshop perform assembly work on the axle housing. Do not perform any welding on the axle housing. Do not have any welding performed on the axle housing. In case of doubt, contact the trailer manufacturer.



## 11 Suspension connection, front

### Replacing the 3D bushing



#### WARNING!

An incorrect installation position or severe wear of the 3D bushing can negatively affect the function of the suspension connection and therefore road safety. There is a risk of accident. Have a qualified workshop regularly perform test and maintenance work in accordance with the test and maintenance schedule. Pay attention to the correct installation position during the installation of a 3D bushing. Make sure that the threaded connection is properly performed employing the tightening torque/angle tightening method.

- ▶ Pay attention to the line mark on the 3D bushing. This line mark must align with the weld seam on the trailing arm after installation (pay attention to figure). Maximum tolerance:  $\pm 2^\circ$
- ▶ Avoid damage to the trailing arm. Therefore, use the “Extraction and insertion tool for the 3D bushing” for removing and installing the 3D bushing JAW 02 705 112 00. (▶ Page 52).
- ▶ Observe the complete instructions on installation/removal of the 3D bushing at the website [www.jost-axle-systems.com](http://www.jost-axle-systems.com), menu item Service.
- ▶ Position the JOST Extraction and insertion tool for 3D bushings JAW 02 705 112 00 at the trailing arm as described in the complete instructions.
- ▶ Heat the trailing arm with a hot air gun to approximately  $80^\circ\text{C}$  before removing the 3D bushing.

- ▶ Use only quick diffusing rubber mounting paste JAE 00 405 100 51 to install the 3D bushing, no grease or oil.
- ▶ Don't use the “Extraction and insertion tool for the 3D bushing” JAW 02 705 112 00 with an impact wrench.



Observe the line mark!

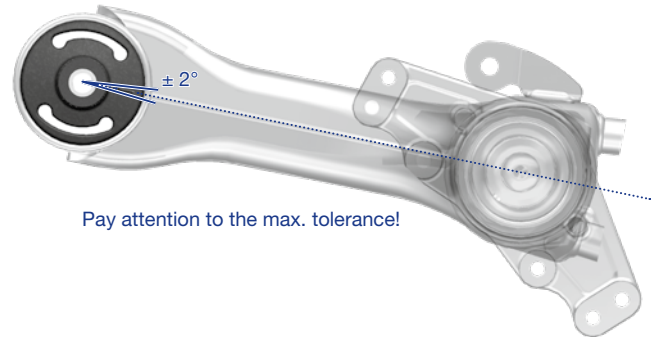

Pay attention to the max. tolerance!

## 11 Fahrwerksanbindung vorn

- Install the plastic wear plates as protecting elements between the 3D bushing and the bearing bracket.



### HINWEIS!

The 3D bushing inside the trailing arm is part of the suspension and is responsible for a safety and comfortable performance of the trailer. Wear plates cover up the housing of the trailing arm and protect the side walls of the hanger bracket from mechanical damages.

In direction of travel (horizontal) the 3D bushing is stiffer as vertical. Depending on the application of force, based on the central position, horizontal total deflections of ( $\pm$ ) 10mm can be possible.

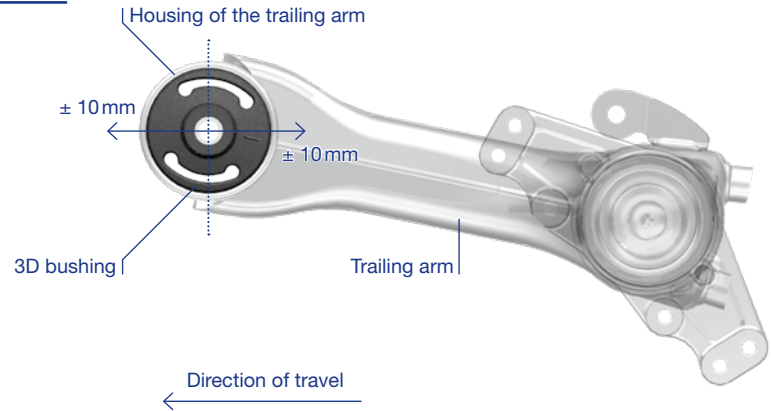

## 11 Suspension connection, front

### Replacing the threaded connection of bearing bracket\*

- ▶ Always mount the threaded connection for bearing bracket/3D bushing using the tightening torque/angle tightening method (▷ Page 56).
- ▶ Always use a new threaded connection. Never use previously used threaded connections during the tightening torque/angle tightening method.
- ▶ In the process, do not use any grease or lubrication on the thread.
- ▶ Tighten the threaded connection at the ride height of the trailer.
- ▶ Initial torque with torque wrench at 400 Nm.
- ▶ Final torque with tightening angle 180° (= 3 nut corners).
- ▶ A test of the new threaded connection prepared as specified is not required. If a test is required later: If the initial tightening torque of the threaded connection is correct, the test tightening torque is 600 Nm. In this context, please observe the test procedure for threaded connections (▷ Page 57).

\*Valid for original JOST parts. With the use of alternative bearing brackets, observe the deviating notes from the trailer manufacturer.

- ▶ Observe the prescribed tightening processes (▷ Page 54).

### Tightening torques

	C	C+D
A	450 Nm	–
B	–	400 Nm + 180°*
C	450 Nm	–

\*applies to original JOST parts.

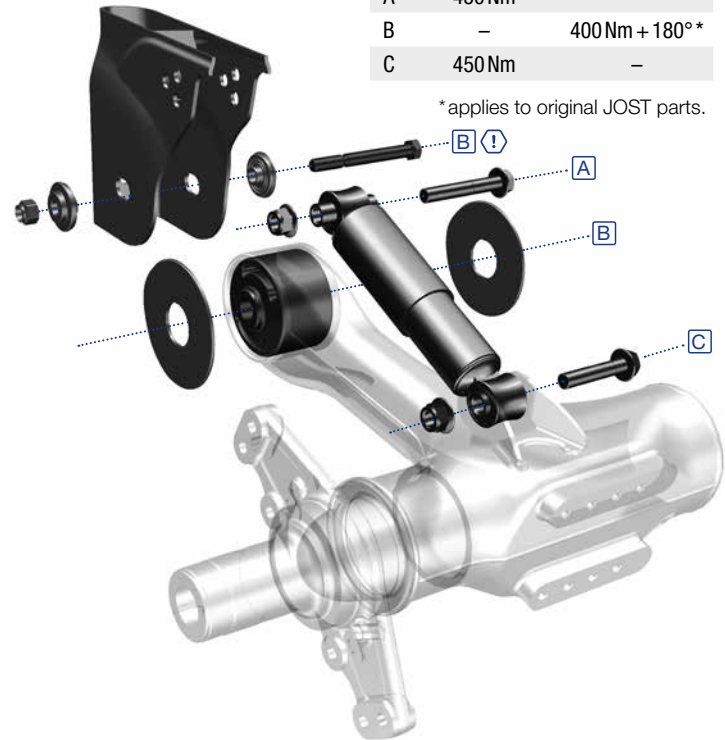

## 11 Suspension connection, front

### Replacing the shock absorbers



#### **WARNING!**

An incorrect installation position or severe wear of the shock absorbers can negatively affect the function of the suspension connection and therefore road safety. There is a risk of accident. Have a qualified workshop regularly perform test and maintenance work in accordance with the test and maintenance schedule. Observe the information label/the recess/mark on the shock absorber. Pay attention to the correct installation position during the installation of new shock absorbers.

- ▶ Observe the adhesive information label on the shock absorber as well as the recess/the mark.
- ▶ The information label/the recess/the mark must point downwards in the direction of the floor after the installation.

#### **Complete information on the Internet**

- ▶ Observe the complete repair description at [www.jost-axle-systems.com](http://www.jost-axle-systems.com), menu item Service.

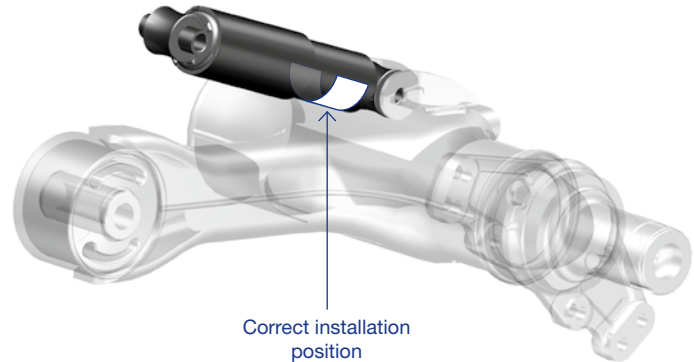



## 12 Suspension connection, rear



### WARNING!

Replacing air bellows supports can change the suspension geometry. Changes in suspension geometry negatively affect road safety. There is a risk of accident. Always use identical original JOST air bellows supports. Make sure that the replacement part numbers on the air bellows supports are identical.



### WARNING!

To change over from a steel- to an aluminum air bellows support is only possible with air bellows support type A (casting marking ... 1241) in combination with an original JOST Ø 300 air bellows (plastic bottom) with offset 20mm. Do not install with offset 60mm.

### Complete information on the Internet

- Observe the complete repair description at [www.jost-axle-systems.com](http://www.jost-axle-systems.com), menu item Service.

### Tightening sequence for air bellows support screws/bolts

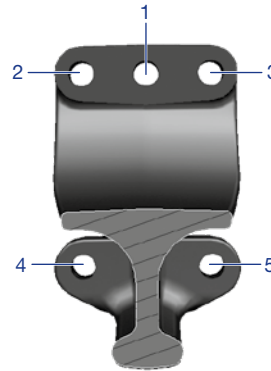

### Tightening torques



#### For steel air bellows support

The following applies to M14 threaded connections (SW21): 100 Nm + 60° for all screws in sequence 1 to 5

The following applies to M16 threaded connections (SW24): 100 Nm + 90° for all screws in sequence 1 to 5

#### For aluminum air bellows support

The following applies to M14 threaded connections (SW21): 100 Nm + 80° for all screws in sequence 1 to 5

- Please note: The contact surface of the air bellows support to the axle housing must be free from paint and dirt.
- Always use a new threaded connection. Never use previously used threaded connections during the tightening torque/angle tightening method.
- Always mount the threaded connections using the tightening torque/angle tightening method in sequence 1 to 5 (method ► Page 54).

## 12 Suspension connection, rear

### Attachment of the air bellows

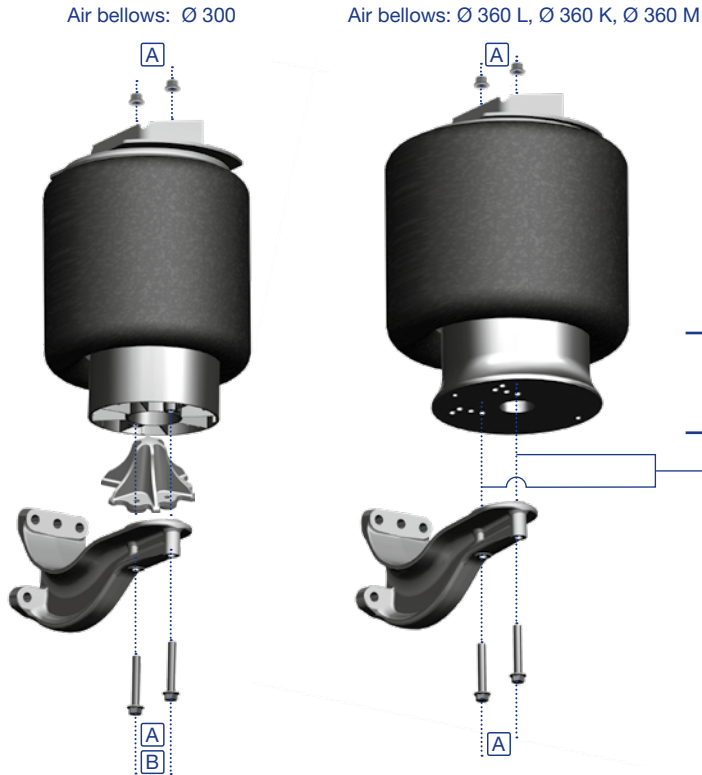

### Tightening torques

A	60 Nm	–
B	80 Nm combined with centering cone	–

- Observe the specified tightening methods (► Page 54).



### NOTE!

When screwing in Ø 360 air bellows, use only the inner row of drill holes of the air bellows piston.

## 13 Wheel hub

### Notes on removing/installing the wheel hub with compact bearing unit



#### WARNING!

You can damage the compact bearing unit in the event of improper installation or removal. There is a risk of accident when driving with a damaged compact bearing unit. Please observe the notes on installation and removal of the wheel hub with compact bearing unit. Always use the two specified special tools. This way you prevent damaging the bearing during removal and installation.



#### NOTE!



The engraving on the left axle spindle indicates the left-hand thread.



A groove at the rear marks the hexagon nut with collar with left-hand thread.

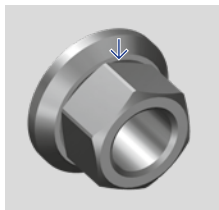

Lightly lubricate the friction surface between pressure plate and nut, but not the thread.

- ▶ Please note: No bearing play can be adjusted in compact bearing units.
- ▶ Burnt grease, possibly caused by brake problems, is an indicator of an imminent or already existing bearing damage. In this case, replace the wheel hub with compact bearing unit for safety reasons.

Recommendation: Contact the Service-Hotline of JOST Achsen Systeme directly if the following happens at the wheel hub with compact bearing unit:

- You notice that an increased amount of grease is leaking
- You notice burnt grease
- Observe bearing play
- You turn the compact bearing by hand and, while doing so, hear grinding sounds or the bearing feels rough.

Always contact the Service Hotline, if one of the above problems occurs, if there are specific doubts or if you feel unsure.

Contact Data of Service Hotline:

[www.jost-axle-systems.com](http://www.jost-axle-systems.com), menu item Contact.

The JOST Achsen Systeme service expert will check with you over the phone what needs to be done.

## 13 Wheel hub

- ▶ Use the special tool “JOST Socket wrench for original JOST hexagon nut with collar JAW 02 703 110 00” (▶ Page 52)
- ▶ Use the special tool “JOST Assembly aid for original JOST 9t hub assemblies with compact bearing JAW 02 703 108 00” (▶ Page 52)
- ▶ Please note during removal: The threaded connection is secured. Turn the nut in the release direction without opening bent flange (pay attention to left and/or right-hand thread). The nut is always damaged when it is released. Therefore, when you release the hexagon nut with collar, always use a new hexagon nut with collar for the new threaded connection.
- ▶ Always use a new threaded connection to fasten the brake disc on the hub assembly. Never reuse a used threaded connection for the tightening torque/angle tightening method.
- ▶ When securing the brake disc, note the different bolt lengths depending on the version of the wheel hub.
- ▶ To determine the correct screws, refer to the Part Finder [jost-part-finder.com](http://jost-part-finder.com)
- ▶ Before you reinstall the wheel hub with compact bearing unit, coat the axle journal with high temperature assembly paste JAE 00 403 080 51.
- ▶ Observe the tightening torque for the axle nut (hexagon nut with collar M80 x 1.5) = 800 Nm.
- ▶ When mounting the hub assembly, always use a new Ø 80 O-ring JAE 02 103 097 48.
- ▶ Observe the tightening torque for the wheel nut wheel nut M22 = 600 Nm. Lightly oil the friction surface between pressure plate and nut, but not the thread.
- ▶ Observe the following during the installation/when creating a new threaded connection: Carefully slide the wheel hub with compact bearing unit onto the axle journal always using the special tool “JOST Assembly aid for original JOST 9t hub assemblies with compact bearing”. Start by tightening the hexagon nut with collar by hand. For subsequent tightening, always use the special tool “Socket wrench for hexagon nut with collar” M80 x 1.5 as well as a professional torque wrench. When tightening the nut with the torque wrench, continue turning the hub unit by hand for a total of 10 revolutions. You will thus prevent future settling in the compact bearing unit. Therefore, tighten the hexagon collar nut carefully and incrementally with the torque wrench to 800 Nm and secure the hexagon collar nut as described on Page 37. (▶ Page 37).
- ▶ Check the correct seating of the axle nut. This must not protrude past the axle spindle. Check that the installed hub unit is seated correctly. Tilting play is not permissible.
- ▶ Use the “JOST hub cap fitting drift for original JOST hub caps for 9 t hub assembly with compact bearing JAW 02 703 119 00” to refit the hub cap.

## 13 Wheel hub

- ▶ Securing the hexagon nut with collar:
  - The left side of vehicle has a left-hand thread. Secure the hexagon nut with collar with the chisel in the release direction in the groove to the right, in other words opposite to the direction of travel (see figure for left-hand thread).

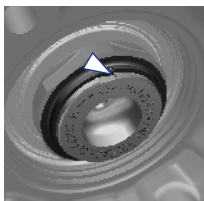

← Direction of travel

- The right side of vehicle has a right-hand thread. Secure the hexagon nut with collar with the chisel in the release direction in the groove to the left, in other words opposite to the direction of travel (see figure for right-hand thread).

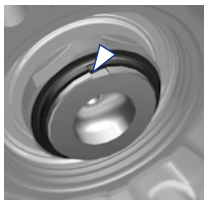

→ Direction of travel

### Complete information on the Internet

- ▶ Observe the complete repair description at [www.jost-axle-systems.com](http://www.jost-axle-systems.com), menu item Service.

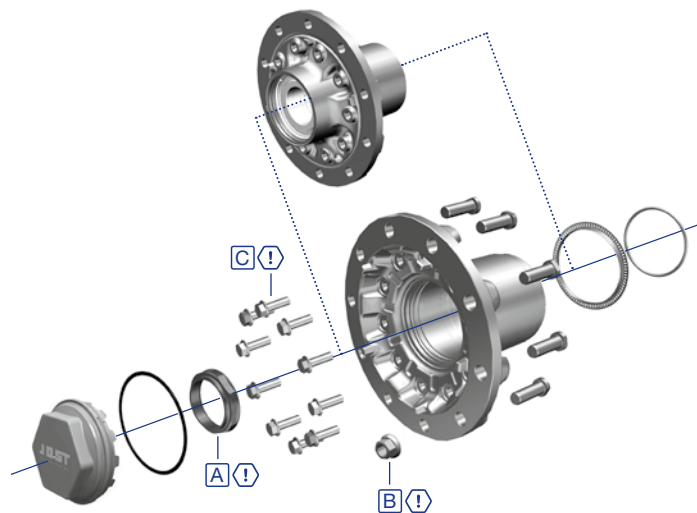

### Tightening torques

	<span style="border: 1px solid black; padding: 2px;">C</span>	<span style="border: 1px solid black; padding: 2px;">C+B</span>
A	800 Nm	–
B	600 Nm	–
C	60 Nm + 60°	

- ▶ Observe the specified tightening methods (▶ Page 54).

### Brake system

The information below refers to Knorr-Bremse and Haldex disc brakes with model series SN6 (TDB 0874)/SN7 (TDB 0876)/SK7 (TDB 0875)/DCA-L7 (TDB 0877)/DCA-T7 (TDB 0883)



#### **WARNING!**

Poor or irregular maintenance as well as improperly performed work on the brake system negatively affects the functional capability of the entire brake system. The entire brake system can fail. There is a risk of accident. Please make sure that test and maintenance work is performed and observe the maintenance intervals as per the test and maintenance schedule of the manufacturer. Please also observe the test and maintenance specifications of the trailer manufacturer. Always have a qualified workshop perform any maintenance and assembly work on the brake system. After any maintenance or assembly work, check the brake function and the system behavior before starting to operate the vehicle.



#### **WARNING!**

The brake system is under pressure. High forces are acting on the components of the brake system. There is a risk of accident and injury. There is the risk of death if work on the brake system is not performed properly. Exclusively have a qualified workshop perform any maintenance and assembly work on the

brake system. Before working on parts of the brake system carrying compressed air, let the pressure escape completely and in a controlled way. Recommendation: For reasons of safety, use only JOST original replacement parts. Use suitable tools. Keep a safe distance, in particular from the piston rods of the brake cylinders, levers and other moving parts of the brake system.

- ▶ When working on the brakes SN6/SN7/SK7/DCA-T7, it is imperative that you observe the complete Knorr-Bremse service instructions on the [www.knorr-bremsecvs.com](http://www.knorr-bremsecvs.com) website. Click on the Downloads tab followed by the Download Documentation item. Select the product category Disc Brakes and the Service Manual document type. Select the PDF file "Air Disc Brake SN6-SN7-SK7". The document contains information of the disc brakes SN6/SN7/SK7. Take the same way to find information about the DCA-T7 but select the PDF file "ST7 Service Manual".
- ▶ When working on the JOST DCA-L7 brake, it is imperative that you observe the complete service instructions on the [www.jost-axle-systems.com](http://www.jost-axle-systems.com) website, menu item Service.



If you have questions, please contact the vehicle manufacturer directly or the Service Hotline at JOST Achsen Systeme: [www.jost-axle-systems.com](http://www.jost-axle-systems.com), menu item Contact.

## 14 Brake

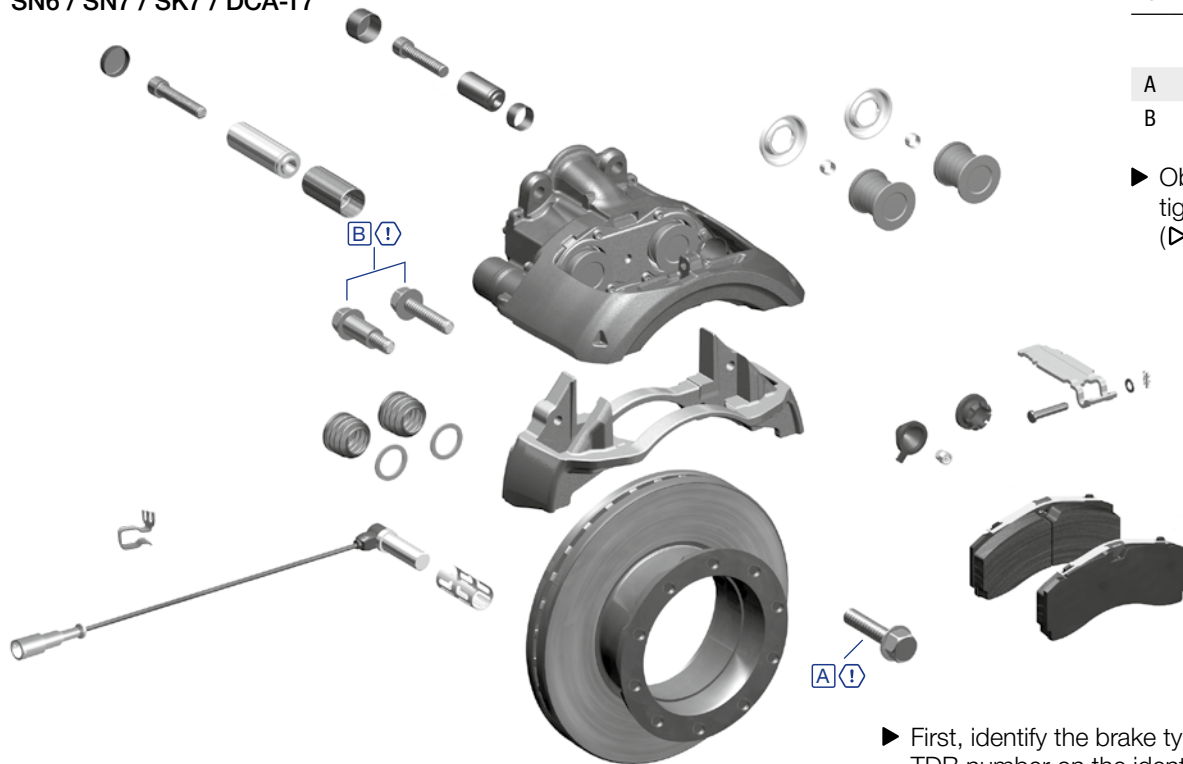
SN6 / SN7 / SK7 / DCA-T7



### Tightening torques

		
A	–	60 Nm + 60°
B	260 Nm	–

► Observe the specified tightening methods (► Page 54).



► First, identify the brake type with the TDB number on the identification plate.

## 14 Brake

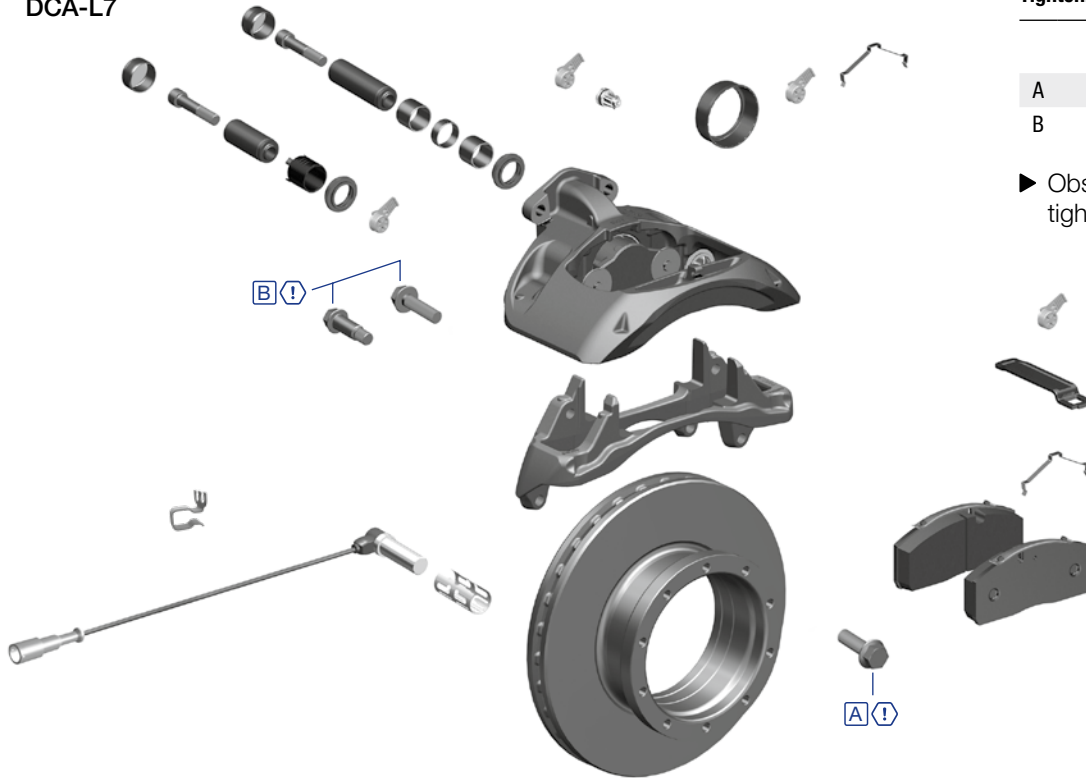
DCA-L7



### Tightening torques

		
A	–	60 Nm + 60°
B	260 Nm	–

► Observe the specified tightening methods (► Page 54).

- First, identify the brake type with the TDB number on the identification plate.
- When working on the DCA-L7, it is imperative that you observe the complete service instructions on the [www.jost-axle-systems.com](http://www.jost-axle-systems.com) website, menu item Service.



## 15 Brake cylinder

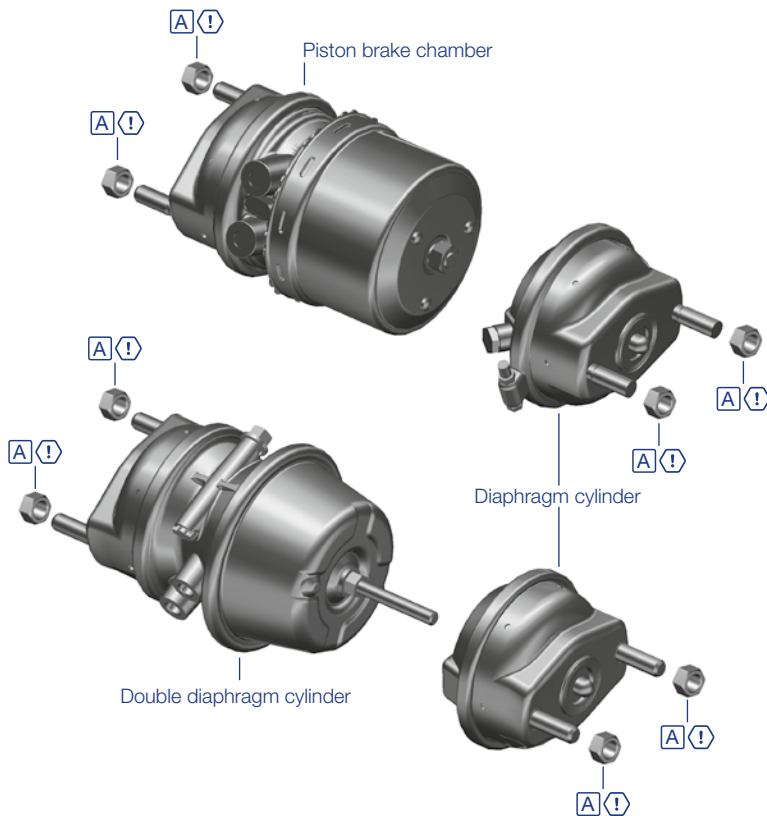

- ▶ Identify the brake cylinder installed using the replacement part number on the identification plate of the brake cylinder.
- ▶ Only replace a brake cylinder with a perfectly identical original brake cylinder.

### Tightening torques

A	180Nm	–

- ▶ Observe the specified tightening methods (▶ Page 54).

## 16 DCA Steermaster 21 (steering axle)



### WARNING!

Changes to the axle configuration negatively affect road safety. There is a risk of accident. Therefore, never change the configuration of the vehicle manufacturer (exception: overall toe-in within the defined limits).

You can identify the steering axle by the model designations D749310, D749311

- ▶ Observe the lubrication interval in accordance with the test and maintenance schedule (▶ Page 58). Relieve the axle during the lubrication process.
- ▶ Use the JOST high-performance lubricant ROE 96017.
- ▶ You can adjust the overall toe-in via the eccentric bush to values from 0 to +4 mm/m.

### Complete information on the Internet

- ▶ Observe the complete service instructions on the [www.jost-axle-systems.com](http://www.jost-axle-systems.com) website, menu item Service.

### Tightening torques

A	25 Nm	–	–
B	50 Nm	–	–
C	85 Nm	–	–
D	110 Nm	–	–
E	145 Nm	–	–
F	320 Nm	–	–
G	–	–	100 Nm - 90°

- ▶ Observe the specified tightening methods (▶ Page 56).

### Tightening process H:

- ▶ Make sure the steering axle is relieved.
- ▶ Screw the clamp nut with a torque wrench to a tightening torque of 650 Nm.
- ▶ Loosen the clamp nut until you see a little gap between clamp nut and pressure plate.
- ▶ Screw the clamp nut finger-tight until it comes in contact with the pressure plate.
- ▶ Loosen the clamp nut by an angle of 20°.
- ▶ Check if it is possible to move the steering knuckle easily, otherwise the procedure must be repeated from “Screw the clamp nut finger-tight”.
- ▶ Secure the clamp nut by caulking with a chisel the flange of the clamp nut into the groove of the kingpin.

## 16 DCA Steermaster 21 (steering axle)

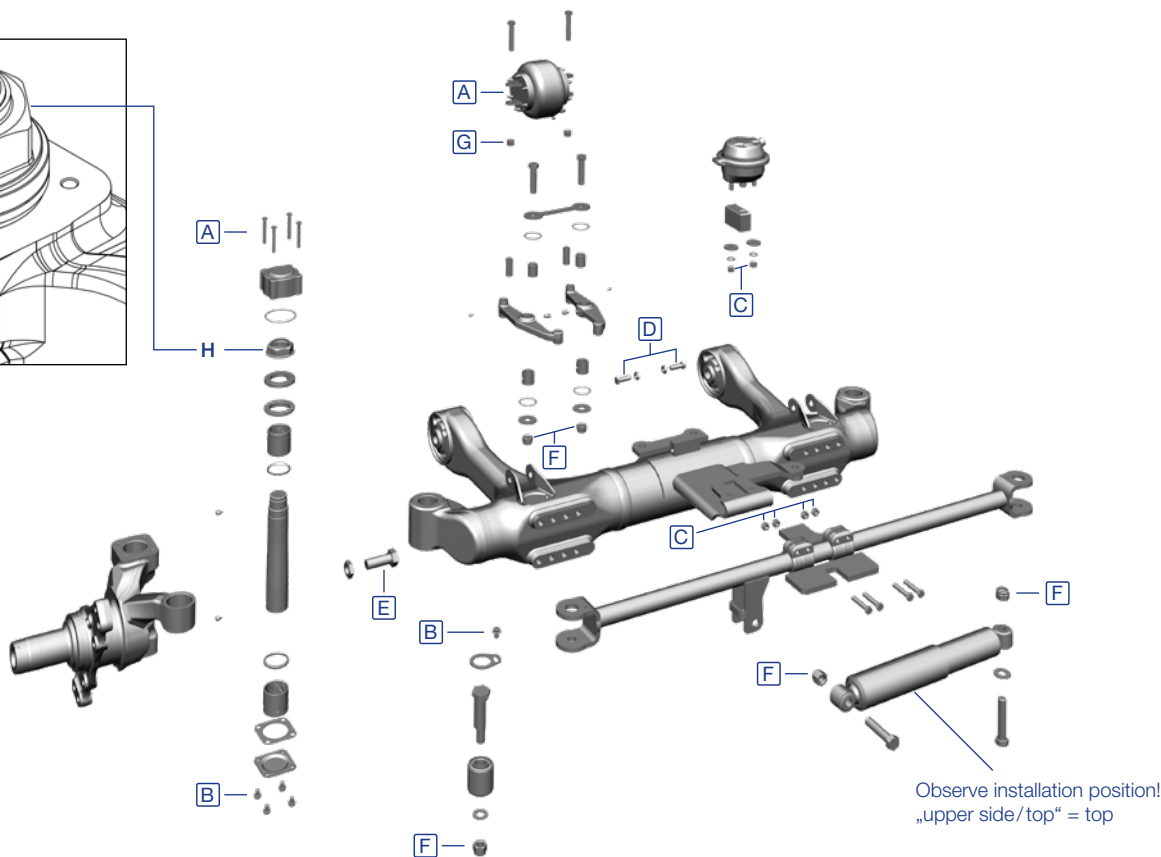
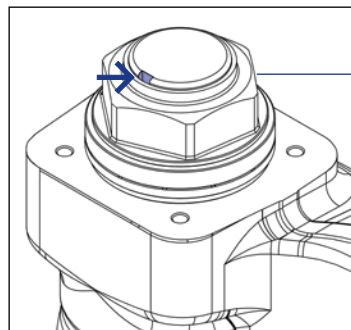

## 17 DCA Airmaster (axle with compressed air reservoir)



### WARNING!

The axle housing is under pressure. In particular on the axle system with compressed air reservoir (DCA Airmaster), welding can cause irreparable damage to the internal coating of the system. Operational safety is no longer ensured in this case. Improperly performed work on the axle housing can pose a hazard to your life and the life of others. There is a risk of accident. Please exclusively have a qualified workshop perform assembly work on the axle housing. Before performing assembly work on the axle housing, properly disconnect the compressed air supply and let any existing compressed air escape from the axle housing completely and in a controlled manner. Do not perform any welding on the axle housing. Do not have any welding performed on the axle housing. In case of doubt, contact the trailer manufacturer.

- ▶ Do not install a mid-lift on this axle. Welding required for this could destroy the internal coating of the axle housing.
- ▶ For the operation, please observe the notes on draining the axle housings before starting to drive (▶ Page 16)

You can identify the axle with compressed air reservoir by the model designations D749360/D749361 as well as by the following information label:

<b>JOST</b> <i>Engineered by Mercedes-Benz</i>		
<b>Max. Operating Pressure PS</b>	<b>20 bar</b>	
<b>Max. Operating Temperature Tmax</b>	<b>60 °C</b>	
<b>Min. Operating Temperature Tmin</b>	<b>- 40 °C</b>	
<b>Volume V</b>	<b>40</b>	<b>Liter</b>

[www.jost-axle-systems.com](http://www.jost-axle-systems.com)

### Complete information on the Internet

- ▶ Observe the complete service instructions on the [www.jost-axle-systems.com](http://www.jost-axle-systems.com) website, menu item Service.

## 17 DCA Airmaster (axle with compressed air reservoir)

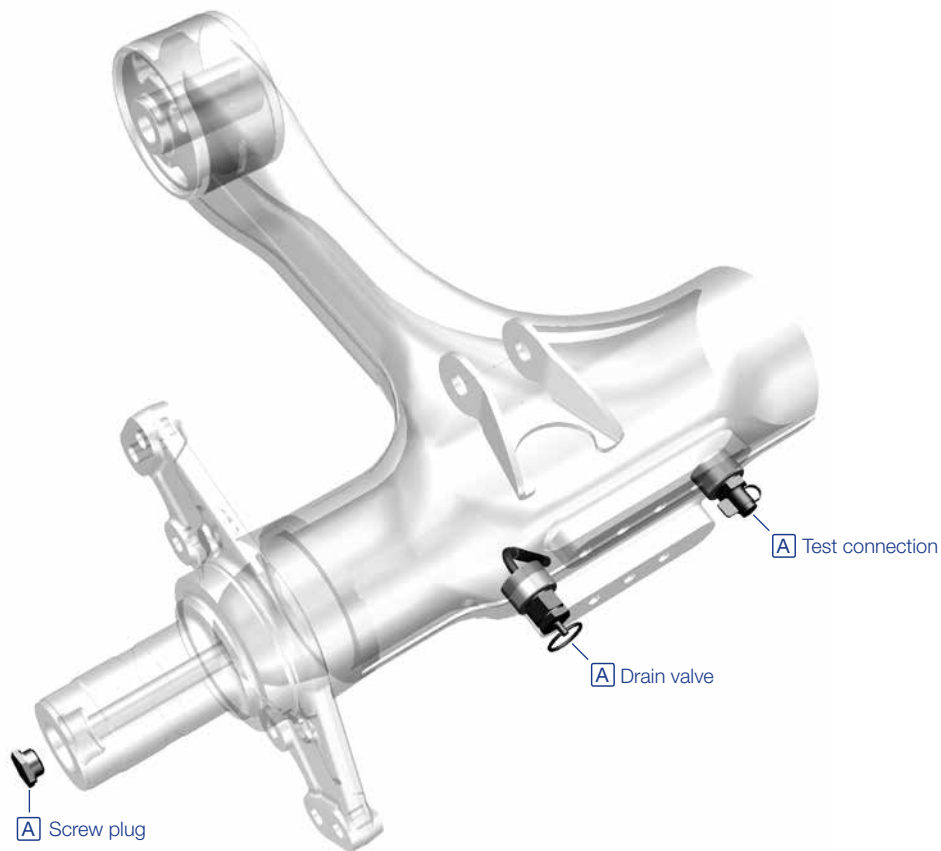

### Tightening torques

		
A	40Nm	–

- ▶ Observe the specified tightening methods (▶ Page 54).

### Note

- ▶ Items test connection and drain valve can be switched.

## 18 Tyre inflation system (RFS)

The RFS preparation (preparation for tyre inflation system) is an option for DCA axles.

You can identify the RFS preparation by the model designations D749368/D749369 as well as by the following information label:



### WARNING!

The axle housing is under pressure. There is the risk of death if work on the axle housing is not performed properly. Exclusively have qualified workshops perform any maintenance work on the axle housing. Before performing assembly work on the axle housing, properly disconnect the compressed air supply and let any existing compressed air escape from the axle housing completely and in a controlled manner.



### WARNING!

There is the risk of death in the event of improper use of the compressed air connections. Use the compressed air connections of the RFS preparation exclusively to connect a proper RFS system. Never connect the compressed air connections of the RFS preparation to a brake or air suspension system or other compressed air-operated equipment.

- ▶ Please note: The maximum permissible static operating pressure of a DCA trailer axle with RFS preparation is 12 bar.
- ▶ Please note: The tightening torque of the compressed air connections (M22 x 1.5) is 40 Nm.
- ▶ Please note: The RFS system provider/trailer manufacturer is responsible for the functional coordination and use of the connections.
- ▶ If an RFS system is installed: Please observe the supplemental maintenance procedures of the RFS system provider/trailer manufacturer.

## 19 Lift systems

### Complete information on the Internet

- Observe the complete service instructions on the [www.jost-axle-systems.com](http://www.jost-axle-systems.com) website, menu item Service.



#### WARNING!

There is a danger of crushing in the entire axle area during lowering/lifting of the axle. Keep an adequate safe distance.

### DCA mid-lift



#### WARNING!

There is a risk of accident if the DCA mid-lift is improperly installed at the axle housing. Exclusively have a DCA mid-lift installed or repaired by the vehicle manufacturer. Do not install a mid-lift on axles with compressed air reservoir of model designations D749360 or D749361.

### 19.1 DCA mid-lift

#### Tightening torques

A	60 Nm	–

- Observe the specified tightening methods (► Page 54).

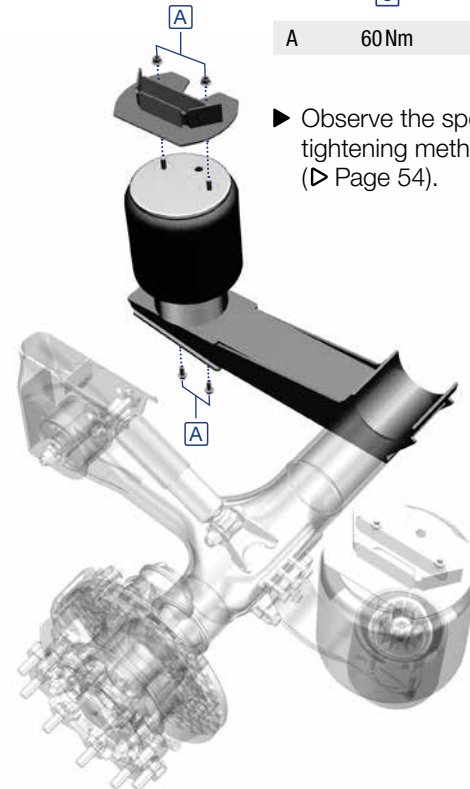

## 19 Lift systems

### 19.2 DCA twin lift

Version as of 11/2018

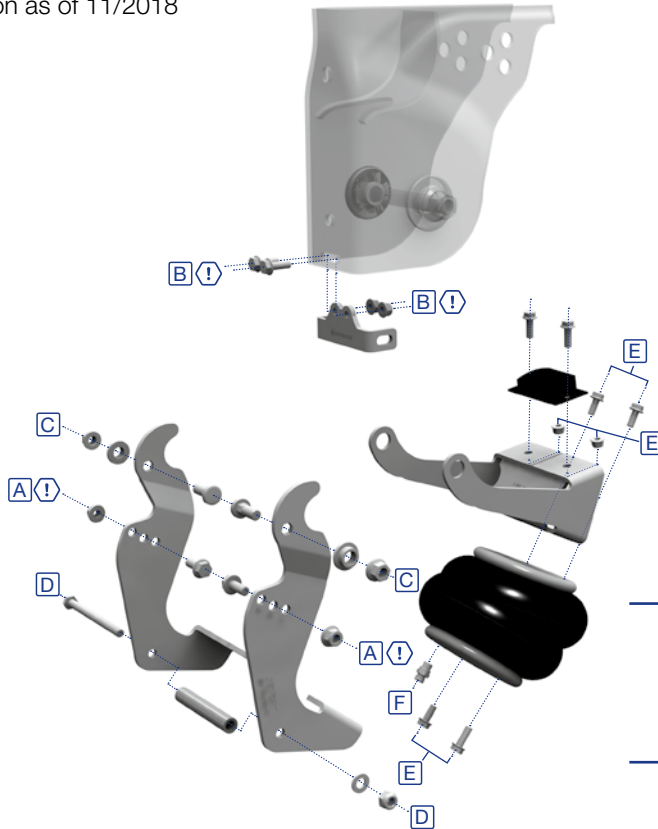

#### Tightening torques

A	150 Nm	–
B	80 Nm	–
C	180 Nm	–
D	60 Nm	–
E	30 Nm	–
F	20 Nm	–

► Observe the specified tightening methods (► Page 54).



#### NOTE!

The staking positions A, B, C have not changed in comparison to lift version 30 70 version from 01-2008. Thus it is possible to install both types of lift (30 70/31 70) on one axle.



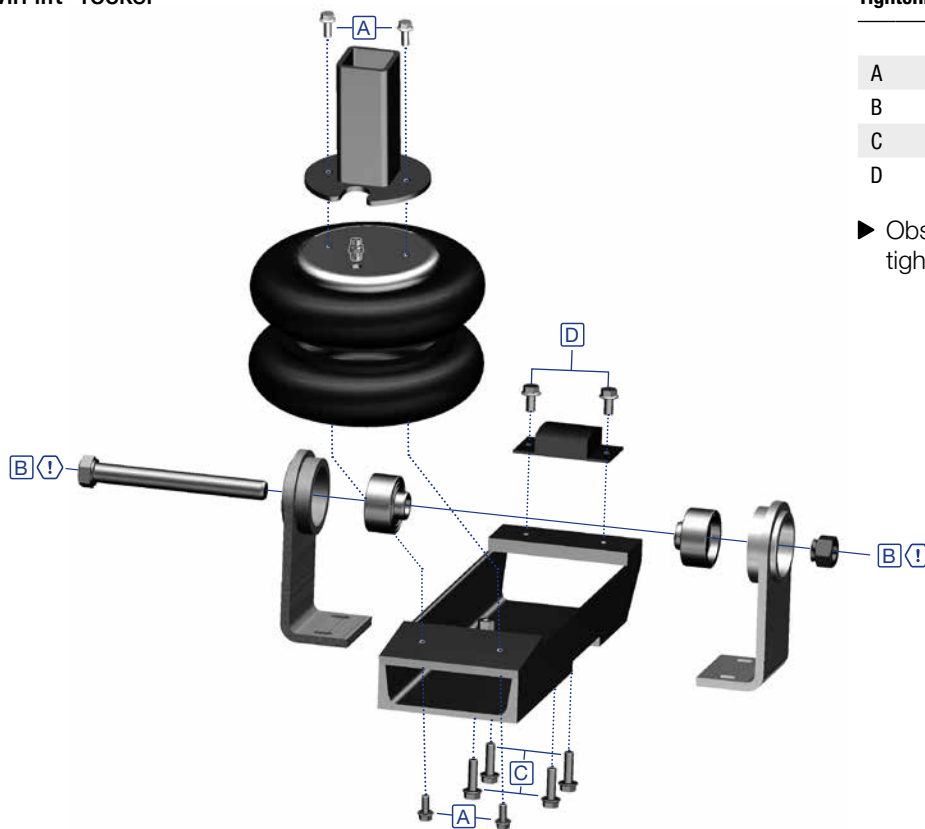

## 19 Lift systems

### 19.3 DCA twin lift “rocker”



#### Tightening torques





		
A	25 Nm	–
B	–	400 Nm + 180°
C	55 Nm	–
D	50 Nm	–

- Observe the specified tightening methods (► Page 54).

## 20 Test and maintenance schedule for DCA trailer axles

For JOST trailer axles, version: compact bearing (DCA),  
9 to, use in normal operation,

Model designation: 749.324, 749.325, 749.334, 749.349,  
749.360, 749.361, 749.368, 749.369, 749.310, 749.311  
(as at: April 2018)

Check/test procedure	A every three months*, or every 25.000 km	B annually*, or every 100.000 km
<b>Brake</b>		
Visual inspection of the components for damage/wear, especially the safety-relevant threaded connections		
Brake lining thickness	●	
Brake disc	●	
Unobstructed movement of brake caliper		●
Clearance of brake caliper		●
Bearing play of brake caliper		●
Brake caliper seals		●
Brake caliper threaded connection 		●
Threaded connection, hub/brake disc 		●
Threaded connection, brake cylinder 		●
<b>Suspension</b>		
Visual inspection of the components for damage/wear, especially the safety-relevant threaded connections		
Retaining bracket at frame		●
Retaining bracket threaded connection 		●
Plastic wearing washers at retaining bracket		●
3D bushing		First inspection after 4 years, then annually.
Shock absorber		●

## 20 Test and maintenance schedule for DCA trailer axles

### Further information on the Internet

- You can find a test and maintenance record as a checklist for completion at [www.jost-axle-systems.com](http://www.jost-axle-systems.com), menu item Service, as well as from (► Page 58)

Check/test procedure	A every three months*, or every 25.000 km	B annually*, or every 100.000 km
Air bellows		●
Air bellows threaded connection at axle housing		●
<b>Wheel circumference</b> Visual inspection of the components for damage/wear, especially the safety-relevant threaded connections		
Retainer, hexagon nut with collar 		●
Compact bearing unit		●
<b>Wheel nuts</b> Check for specified tightening torque after first drive with load (after approx. 50 km) and after every wheel replacement		
<b>Steering axle</b> Visual inspection of the components for damage and wear		
Steering knuckle bearing, Steering damper		●
Locking mechanism	●	
Lubrication of the plain bearing lubrication points (axle unloaded/raised)	●	

\* Required intervals and work depend on the type of vehicle, individual usage and operating conditions. This test and maintenance schedule was created for the use in normal operation (asphalt/

concrete roads). Test and maintenance schedules for vehicles that are operated under different operating conditions can be found at [www.jost-axle-systems.com](http://www.jost-axle-systems.com), menu item Service.

## 21 Special tools for maintenance and repair

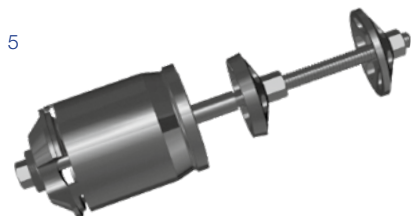
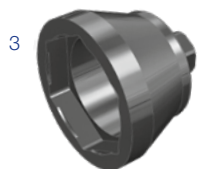

Item	Description	Order No.
1	Assembly aid for compact bearing hub	JAW 02 703 108 00
2	Fitting drift for the hub cap installation	JAW 02 703 119 00
3	Socket wrench for hexagon nut with collar	JAW 02 703 110 00
4	Fitting drift for ABS ring	JAW 02 703 109 00
5	Extraction and insertion tool for 3D bushings	JAW 02 705 112 00
6	Hand pump	JAW 02 705 116 00
7	Cylinder	JAW 02 705 114 00
8	Hydraulic hose	JAW 02 705 115 00



## 22 Warranty

### Prerequisites for warranty

Please observe the notes in these guidelines as well as the notes of the trailer manufacturer on the proper operation of your axle system as well as on possible vehicle damage.

Your warranty claims can be further limited,

- If you use faulty/low-quality replacement parts.
- If you use special additives. Special lubricant additives are not required for DCA trailer axles.
- If you use cleaning agents that do not have a neutral pH value that might destroy the corrosion protection.

### Warranty processing

Make sure to submit your **warranty claim prior to the repair**.

You can submit your warranty claim directly to JOST Achsen Systeme. For additional questions regarding warranties, contact one of the country specific points of contact that are listed on page 67 of this Guideline.

Observe the guideline for warranty processing on the [www.jost-axle-systems.com](http://www.jost-axle-systems.com) website under menu item Service. Observe the link to the download area. This is where you will find claim forms and claim conditions.



### 23.1 Prescribed tightening processes



#### **WARNING!**

Threaded connections that are faulty, not adequately tightened, tightened too much or damaged negatively affect the operational safety of your vehicle. There is a risk of accident. You endanger your life and the life of other road users. Observe the specified tightening methods for threaded connections. Do not use any grease/lubrication on the thread. Never use any previously used threaded connection during the tightening torque/angle tightening method.

Observe the following three tightening methods for threaded connections:

- Tightening torque/angle tightening method  (▷ Page 54).
- Tightening torque/angle loosen method  (▷ Page 56).
- Simplified tightening torque method  (▷ Page 56).

#### **Safety-relevant threaded connections**

Please observe the particularly safety-relevant threaded connections, which are marked with  in this booklet.

#### **Prerequisites for correct threaded connections**

- ▶ When preparing threaded connections, observe the tightening torque values in these guidelines.
- ▶ Always use a professional torque wrench for tightening with tightening torque.

- ▶ Please observe the specifications of the component manufacturers when refinishing components. Keep the threading surfaces free of lacquer.
- ▶ Use high-quality threaded connections. Recommendation: Use JOST original replacement parts. JOST Achsen Systeme cannot assess replacement parts from external sources. JOST Achsen Systeme does not know the torque values permissible or required for replacement parts from external sources and permissible load limits. Significant deviations from JOST original replacement parts are possible. If you do not know the permissible or required tightening processes and torque values as well as the permissible load limits, you can already destroy the threaded connection during threading.
- ▶ In the process, do not use any grease or lubrication on the thread of the threaded connection.

#### **23.2 Tightening torque/angle tightening method**

Exclusively have qualified workshops loosen threaded connections and create new ones using the tightening torque/angle tightening method. These types of connections are marked with  in the booklet. Dispose of the screws/bolts, nuts and other fasteners used after loosening the connection. They must never be reused as their structure is damaged.

## 23 Technical information and data

Please observe the special safety-relevant threaded connections with the tightening torque/angle tightening method in this context

- Threaded connection of the bearing bracket (► Page 31)
- Threaded connection of air bellows support on axle housing (► Page 33)
- Threaded connection of hub/brake disc (► Page 37)
- which are marked with  in this booklet.

Please proceed as follows:

### A) Initial torque with torque

- Set the torque wrench to the specified value. Tighten the threaded connection with the torque wrench until you hear the “click”. Thus, the target value has been reached.

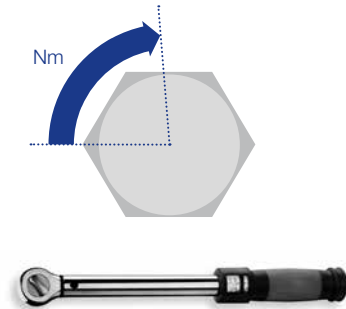

### B) Final torque with tightening angle

- Use a pen to mark the position of the nut (set check mark).
- Continue turning the nut/screw/bolt by the specified angle/the specified number of nut corners. Please observe:  $60^\circ = 1$  nut corner.
- Next, check the position of the nut and the tightening angle based on the check mark you have applied.
  - If the tightening angle has not yet been reached: Carefully continue turning the nut up to the target value, then check the tightening angle.
  - If the target value has been exceeded: It is mandatory that you replace the defective threaded connection with a new threaded connection. Repeat the entire process starting from step 1 (initial torque with torque).

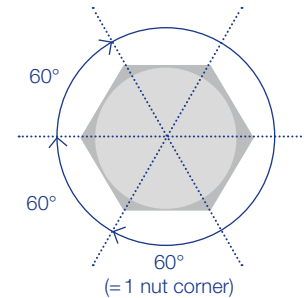

If you proceed as specified, it is not necessary to retighten JOST original threaded connections.

## 23 Technical information and data

### 23.3 Simplified tightening torque method

Only qualified workshops may loosen threaded connections prepared with tightening torque, but without tightening angle, or prepare new ones. These types of connections are marked with  in the booklet. The screws/bolts, nuts and other fasteners used can be reused.

In this context, please observe the particularly safety-relevant threaded connections with simplified tightening torque method, which are marked with  in this booklet:

- Hexagon nut with collar including retainer (▷ Page 37)
- Threaded connection of brake caliper (▷ Page 39)
- Threaded connection of hub/rim (wheel nuts) (▷ Page 37)
- Threaded connection of brake cylinder (▷ Page 41).

Please proceed as follows:

#### Tightening with torque

- ▶ Set the torque wrench to the specified value. Tighten the threaded connection with the torque wrench until you hear the “click”. Thus, the target value has been Nm reached.

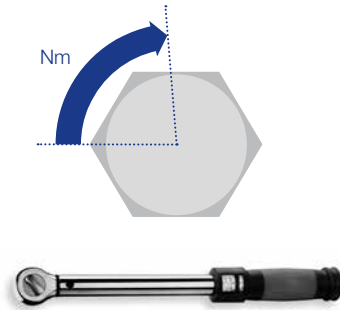

### 23.4 Tightening torque/angle loosen method

#### A) Pre-tightening with torque

- ▶ Set the torque wrench to the specified value. Tighten the threaded connection with the torque wrench until you hear the “click”. Thus, the target value has been Nm reached.

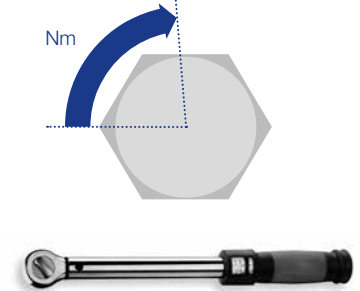

#### B) Loosening with angle

- ▶ Mark the position of the nut with a pen (set control mark).
- ▶ Turn the nut back by the specified angle (loosen).  
Note:  $60^\circ = 1$  nut corner.
- ▶ Next, check the position of the nut and the angle of rotation using the control mark you set earlier.
- If the angle rotation is not reached: Continue carefully to turn the nut back to the target value, then check the angle of rotation.
- If the target value is exceeded: Repeat the entire process starting with Step 1 (tightening with torque).



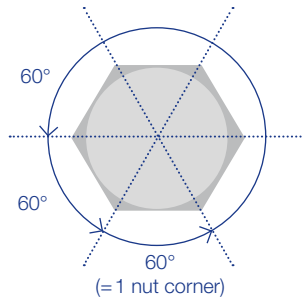

### 23.5 Test procedure for threaded connections

- ▶ Use a pen to mark the position of the nut (set check mark).
- ▶ Set your torque wrench to the check value and carefully try to continue turning the nut until your torque wrench clicks.
- ▶ Next, check the position of the nut based on the check mark you have applied. If the nut has moved slightly, the threaded connection is defective. It is mandatory that you replace the defective threaded connection with a new threaded connection.
- ▶ If the nut has not moved, the threaded connection is OK.

You can find complete tables at the Website [www.jost-axle-systems.com](http://www.jost-axle-systems.com), menu item Service.

### Complete information on the Internet

- ▶ Observe the complete repair description at [www.jost-axle-systems.com](http://www.jost-axle-systems.com), menu item Service.

## 24 Test and maintenance schedule for normal operation

Check/test procedure	every three months, or every 25,000 km	annually or every 100,000 km	after 25.000 km	after 50.000 km	after 75.000 km	after 100.000 km	after 125.000 km	after 150.000 km	after 175.000 km	after 200.000 km	after 225.000 km	after 250.000 km	after 275.000 km	after 300.000 km	after 325.000 km	after 350.000 km	after 375.000 km	after 400.000 km	after 425.000 km	after 450.000 km	after 475.000 km	after 500.000 km	
<b>Brake</b>																							
Visual inspection of the components for damage/wear, especially the safety-relevant threaded connections																							
Brake lining thickness	•																						
Brake disc	•																						
Unobstructed movement of brake caliper		•																					
Clearance of brake caliper		•																					
Bearing play of brake caliper		•																					
Brake caliper seals		•																					
Brake caliper threaded connection		•																					
Threaded connection, hub/brake disc		•																					
Threaded connection, brake cylinder		•																					
<b>Suspension</b>																							
Visual inspection of the components for damage/wear, especially the safety-relevant threaded connections																							
Retaining bracket at frame		•																					
Retaining bracket threaded connection		•																					
Plastic wearing washers at retaining bracket		•																					
3D bushing			First inspection after 4 years, then annually.																				
Shock absorber		•																					
Air bellows		•																					
Air bellows threaded connection at axle housing		•																					
<b>Wheel circumference</b>																							
Visual inspection of the components for damage/wear, especially the safety-relevant threaded connections																							
Retainer, hexagon nut with collar		•																					
Compact bearing unit		•																					
<b>Wheel nuts</b> Check for specified tightening torque after first drive with load (after approx. 50 km) and after every wheel replacement																							
<b>Steering axle</b>																							
Visual inspection of the components for damage and wear																							
Steering knuckle bearing, Steering damper		•																					
Locking mechanism		•																					
Lubrication of the plain bearing lubrication points (axle unloaded/raised)		•																					

<p><b>after 25,000 km</b> Odometer reading: Date: Verified by (signature / stamp):</p>	<p><b>after 125,000 km</b> Odometer reading: Date: Verified by (signature / stamp):</p>	<p><b>after 225,000 km</b> Odometer reading: Date: Verified by (signature / stamp):</p>	<p><b>after 325,000 km</b> Odometer reading: Date: Verified by (signature / stamp):</p>	<p><b>after 425,000 km</b> Odometer reading: Date: Verified by (signature / stamp):</p>
<p><b>after 50,000 km</b> Odometer reading: Date: Verified by (signature / stamp):</p>	<p><b>after 150,000 km</b> Odometer reading: Date: Verified by (signature / stamp):</p>	<p><b>after 250,000 km</b> Odometer reading: Date: Verified by (signature / stamp):</p>	<p><b>after 350,000 km</b> Odometer reading: Date: Verified by (signature / stamp):</p>	<p><b>after 450,000 km</b> Odometer reading: Date: Verified by (signature / stamp):</p>
<p><b>after 75,000 km</b> Odometer reading: Date: Verified by (signature / stamp):</p>	<p><b>after 175,000 km</b> Odometer reading: Date: Verified by (signature / stamp):</p>	<p><b>after 275,000 km</b> Odometer reading: Date: Verified by (signature / stamp):</p>	<p><b>after 375,000 km</b> Odometer reading: Date: Verified by (signature / stamp):</p>	<p><b>after 475,000 km</b> Odometer reading: Date: Verified by (signature / stamp):</p>
<p><b>after 100,000 km</b> Odometer reading: Date: Verified by (signature / stamp):</p>	<p><b>after 200,000 km</b> Odometer reading: Date: Verified by (signature / stamp):</p>	<p><b>after 300,000 km</b> Odometer reading: Date: Verified by (signature / stamp):</p>	<p><b>after 400,000 km</b> Odometer reading: Date: Verified by (signature / stamp):</p>	<p><b>after 500,000 km</b> Odometer reading: Date: Verified by (signature / stamp):</p>

## 24 Test and maintenance schedule for normal operation

Check/test procedure	every three months, or every 25,000 km	annually or every 100,000 km	after 525.000 km	after 550.000 km	after 575.000 km	after 600.000 km	after 625.000 km	after 650.000 km	after 675.000 km	after 700.000 km	after 725.000 km	after 750.000 km	after 775.000 km	after 800.000 km	after 825.000 km	after 850.000 km	after 875.000 km	after 900.000 km	after 925.000 km	after 950.000 km	after 975.000 km	after 1.000.000 km
<b>Brake</b>																						
Visual inspection of the components for damage/wear, especially the safety-relevant threaded connections																						
Brake lining thickness	•																					
Brake disc	•																					
Unobstructed movement of brake caliper		•																				
Clearance of brake caliper		•																				
Bearing play of brake caliper		•																				
Brake caliper seals		•																				
Brake caliper threaded connection		•																				
Threaded connection, hub/brake disc		•																				
Threaded connection, brake cylinder		•																				
<b>Suspension</b>																						
Visual inspection of the components for damage/wear, especially the safety-relevant threaded connections																						
Retaining bracket at frame		•																				
Retaining bracket threaded connection		•																				
Plastic wearing washers at retaining bracket		•																				
3D bushing																						
Shock absorber		•																				
Air bellows		•																				
Air bellows threaded connection at axle housing		•																				
<b>Wheel circumference</b>																						
Visual inspection of the components for damage/wear, especially the safety-relevant threaded connections																						
Retainer, hexagon nut with collar		•																				
Compact bearing unit		•																				
<b>Wheel nuts</b> Check for specified tightening torque after first drive with load (after approx. 50 km) and after every wheel replacement																						
<b>Steering axle</b>																						
Visual inspection of the components for damage and wear																						
Steering knuckle bearing, Steering damper		•																				
Locking mechanism		•																				
Lubrication of the plain bearing lubrication points (axle unloaded/raised)		•																				

<p><b>after 525.000 km</b> Odometer reading: Date: Verified by (signature / stamp):</p>	<p><b>after 625.000 km</b> Odometer reading: Date: Verified by (signature / stamp):</p>	<p><b>after 725.000 km</b> Odometer reading: Date: Verified by (signature / stamp):</p>	<p><b>after 825.000 km</b> Odometer reading: Date: Verified by (signature / stamp):</p>	<p><b>after 925.000 km</b> Odometer reading: Date: Verified by (signature / stamp):</p>
<p><b>after 550.000 km</b> Odometer reading: Date: Verified by (signature / stamp):</p>	<p><b>after 650.000 km</b> Odometer reading: Date: Verified by (signature / stamp):</p>	<p><b>after 750.000 km</b> Odometer reading: Date: Verified by (signature / stamp):</p>	<p><b>after 850.000 km</b> Odometer reading: Date: Verified by (signature / stamp):</p>	<p><b>after 950.000 km</b> Odometer reading: Date: Verified by (signature / stamp):</p>
<p><b>after 575.000 km</b> Odometer reading: Date: Verified by (signature / stamp):</p>	<p><b>after 675.000 km</b> Odometer reading: Date: Verified by (signature / stamp):</p>	<p><b>after 775.000 km</b> Odometer reading: Date: Verified by (signature / stamp):</p>	<p><b>after 875.000 km</b> Odometer reading: Date: Verified by (signature / stamp):</p>	<p><b>after 975.000 km</b> Odometer reading: Date: Verified by (signature / stamp):</p>
<p><b>after 600.000 km</b> Odometer reading: Date: Verified by (signature / stamp):</p>	<p><b>after 700.000 km</b> Odometer reading: Date: Verified by (signature / stamp):</p>	<p><b>after 800.000 km</b> Odometer reading: Date: Verified by (signature / stamp):</p>	<p><b>after 900.000 km</b> Odometer reading: Date: Verified by (signature / stamp):</p>	<p><b>after 1.000.000 km</b> Odometer reading: Date: Verified by (signature / stamp):</p>













## 26 Service Contact

### Head office

#### JOST Achsen Systeme GmbH

Flugplatz 18  
34379 Kassel-Calden, Deutschland  
Tel. +49 (0) 5674 9237-0  
Fax +49 (0) 5674 9237-480  
E-Mail [service-axles@jost-world.com](mailto:service-axles@jost-world.com)

### Region Benelux

#### JOST Achsen Systeme

Flugplatz 18  
34379 Kassel-Calden, Deutschland  
Tel. +49 (0) 5674 9237-0  
Fax +49 (0) 5674 9237-480  
E-Mail [service-axles@jost-world.com](mailto:service-axles@jost-world.com)

### Region Polen

#### JOST Polska Sp. z o.o.

PL - 01-687 Warszawa  
ul. Lektykarska 40  
Tel. +48 22 896 10 77  
Fax +48 22 896 10 76  
E-Mail [servicesaxles@jost-world.com](mailto:servicesaxles@jost-world.com)

### Region Frankreich

#### JOST France S.à.r.l.

91130 Ris-Orangis  
Z.A. Terres Saint-Lazare  
2 Allée Gaillée  
Tel. 0033 1 69 25 93 39  
Fax 0033 1 69 25 87 94  
E-Mail [service-axles@jost-world.com](mailto:service-axles@jost-world.com)

### Region Italien

#### JOST Italia S.R.L.

20090 Cesano Boscone (Milano)  
Via E. De Nicola 28  
Tel. +39 02 4404951  
Fax +39 02 4406201  
E-Mail [service-axles@jost-world.com](mailto:service-axles@jost-world.com)

### Region Southern Europe

#### JOST IBERICA, S.A.

50420 Cadrete (Zaragoza)  
Carretera Valencia, Km 12  
Apdo. Correos 967  
Tel. 0034/976 12 62 22  
Tel. 0034/976 12 61 62  
Fax 0034/976 12 62 12  
E-Mail [service-axles@jost-world.com](mailto:service-axles@jost-world.com)

### Region Russland

#### ООО „ЙОСТ-РУС“

Россия 119530 Москва  
Очаковское шоссе, д. 32, с. 27  
Tel. +7 (499) 917 09 36  
E-Mail [jost.russia@jost-world.com](mailto:jost.russia@jost-world.com)

### Region United Kingdom

#### JOST UK Ltd.

BL3 2JJ Bolton, Lancashire  
Edbro House, Nelson Street  
Tel. +44 (0) 1204 528888  
Fax +44 (0) 1204 531957  
E-Mail [service-axles@jost-world.com](mailto:service-axles@jost-world.com)

[www.jost-axle-systems.com](http://www.jost-axle-systems.com)

Member of **JOST**-World

**JOST**, Germany Tel. +49 6102 295-0, [jost-sales@jost-world.com](mailto:jost-sales@jost-world.com), [www.jost-world.com](http://www.jost-world.com)

**JOST Achsen Systeme**, Germany Tel. +49 5674 9237-0, [sales-axles@jost-world.com](mailto:sales-axles@jost-world.com), [www.jost-axle-systems.com](http://www.jost-axle-systems.com)