



VALX

GOING THE EXTRA MILE

DRIVER MANUAL

Document code: DM 2060-04 Date: September 2020

Dear customer,

Thank you for choosing this VALX product. We will provide you with utmost service.

This Driver Manual is intended to guide you during your journey while using the VALX axles.

*For more information about our products and services, visit our website **www.valx.eu**,*

*call our head office in The Netherlands, **+31 (0)88 405 8800** or one of our local representatives.*

Notes:

.....

.....

.....

.....

.....

Table of contents

1. General instructions	1.1 Use of this manual	3
	1.2 Safety instructions and regulations	4
2. Explanation of the axle type code	2.1 Location of the identification plate	6
	2.2 Information on the identification plate	7
3. Maintenance chart	3.1 Disk brake axle	10
	3.2 Drum brake axle	12
	3.3 Air suspension	14
4. Tightening torques	4.1 Tightening torques disk brake axle	15
	4.2 Tightening torques drum brake axle	16
	4.3 Tightening torques air suspension	17
5. Damaged tyre replacement	5.1 Preparatory actions	20
	5.2 Remove the wheel(s)	21
	5.3 Install the wheel(s)	21
6. Hub cap	6.1 Removing the hub cap.....	22
	6.2 Mounting the hub cap	23
7. Brake wear inspection	7.1 Disk brake axle.....	25
	7.2 Drum brake axle	26
8. 24/7 Breakdown support	27

1. General instructions

1.1 Use of this manual

- This manual is intended to facilitate drivers to operate vehicles fitted with VALX equipment, in an efficient, safe and environmental friendly way.
- Read this manual thoroughly before using the vehicle or before performing any maintenance or repair tasks.
- Keep this manual for future reference. Retain the manual in a safe place in the vehicle.
- Carry out the procedures in the order given. Do not change the order of the steps.
- This manual replaces all previous versions, if any.

Before every journey with the vehicle always make sure that:

- The air springs are inflated.
- Tyres and wheels are undamaged and not worn beyond the legal and / or the technical requirements.
- The tyres are inflated correctly.
- The yellow and red airline are connected properly.
- The ABS / EBS connection is fitted properly.
- There is no audible leakage in the air system.
- All wheel nuts are present and are visually tight.
- The air suspension is in the correct driving height.

When driving:

- The driving behaviour should be adapted to the specific road conditions and the cargo being transported.
- Prevent that brakes get overheated as this will negatively impact brake performance.
- The parking brake should not be used. The parking brake should never be used when brakes are hot because this can lead to extreme damage.

In case of road side repairs:

- If possible park the vehicle in a safe spot.
- Try to alert other drivers by means of warning triangle(s), warning light(s) or other.
- Always wear a high visibility safety vest.
- Secure the vehicle against rolling away.

When loading / unloading:

- Make sure the maximum axle load is not exceeded.
- The weight of the cargo is correctly distributed in the vehicle.
- The truck and trailer are properly supported when loading / unloading heavy goods.

1.2 Safety instructions and regulations

General

- VALX accepts no liability for any damage or physical injury caused by non-compliance with the safety instructions and regulations in this manual, or by carelessness during any maintenance or repair tasks on the VALX product.
- Depending on the trailer type, the specific repair or maintenance tasks that have to be carried out, the workshop conditions, the environmental circumstances and the cargo that may be loaded, additional safety instructions may be applicable. As VALX has no direct control over these specific working conditions or trailer configurations, it is the users sole responsibility to ensure that the national accident prevention guidelines and the local Health and Safety regulations are adhered to. Please inform VALX immediately if you have dealt with unsafe situations that have not been described in this manual.

Decals and instructions on the VALX product

- Decals or instructions fitted on the VALX product are part of the safety features provided. They should not be covered or removed, but must be present and legible throughout the entire life of the product. Damaged or illegible decals and instructions must be replaced or repaired immediately.

Warranty and original VALX parts

- All products of VALX are covered by warranty as stipulated in the “VALX by Warranty Commitment”. The latest “VALX by Warranty Commitment” can be downloaded from our website www.valx.eu.
- Modification and / or conversion of the product without the written consent of VALX is not allowed at the risk of forfeiting all warranty rights.
- When replacing parts, ONLY use original VALX spare parts. Parts approved by VALX for use in trailer axles periodically undergo severe tests. As a result, VALX is able to guarantee the quality of these parts.
- VALX can not assess for every single third-party product whether it can be used for VALX products without any safety risk. This applies even if such products have already been tested by an accredited test authority. Therefore, the warranty becomes null and void if spare parts other than original VALX parts are used.

Maintenance and repair

- In order to maintain the safe operation and the road-worthiness of the trailer, all maintenance tasks must be carried out according to the prescribed VALX service intervals, and in accordance with the operation and service instructions of the trailer builder.
- Maintenance and repair is strictly reserved to trained and qualified service technicians.

Before starting maintenance or repair

- Make sure that the trailer is properly secured against rolling.
- Make sure that unauthorised persons have no access to the working area.
- Make sure that the working area is sufficiently lit and ventilated.
- Dress properly. Do not wear torn or loose fitting clothes, but wear protective clothing. Remove jewelry, watches, etc. to prevent them from being caught in moving parts.
- Wear protective shoes and keep long hair out of the way.

During maintenance or repair

- Stay alert and watch what you are doing. Use common sense. Do not work on the trailer axle when you are tired or have been taking alcohol, medicine or drugs. Do not smoke.
- Use a hoist when lifting heavy parts. Only use suitable and technically perfect lifting devices with adequate lifting capacity built in compliance with all safety regulations. Fastening of loads and instructions to the operator of the lifting device are restricted to experienced personnel who are within sight or sound of the operator of the lifting device.
- Only use tools, parts, materials, lubricants and service techniques that were approved by VALX. Do not use contaminated or used lubricants. Used lubricants,

cleansing agents and expended axle parts must be disposed of in an environmentally safe way.

- Avoid bodily contact with lubricants.
- Never use worn tools and do not leave tools behind on the trailer axle or on the trailer.
- Never weld on any part of the trailer axle or suspension without the prior written permission of VALX.
- Never re-use self-locking fixing materials. Always replace them.

When maintenance or repair is finished

- Inspect the product. Check for damage, leakage or defects. Any part removed for maintenance or repair purposes must be refitted and checked immediately upon completion of the work.
- Do not clear a product for operation unless it was established that it is absolutely safe and in perfect working order.

A contribution to the protection of our environment

Please obtain information about recycling or environmentally friendly processing of parts and materials that have been replaced during maintenance or repair tasks. Almost all used lubricants are considered to be chemical waste. For the disposal of these a specialized company must be contacted.

2. Explanation of the axle type code

2.1 Location of the identification plate

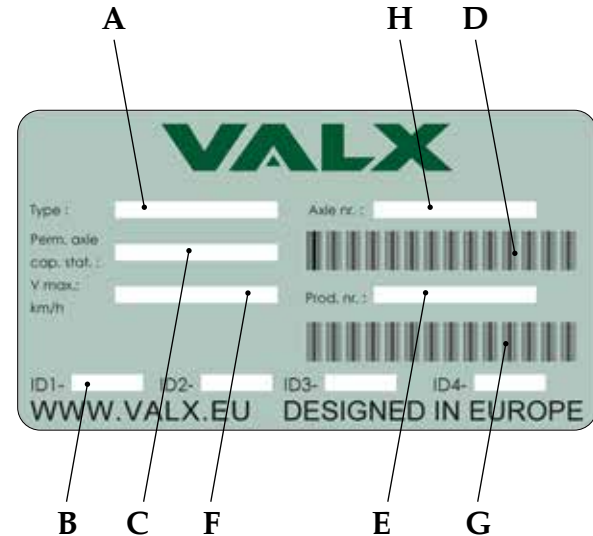
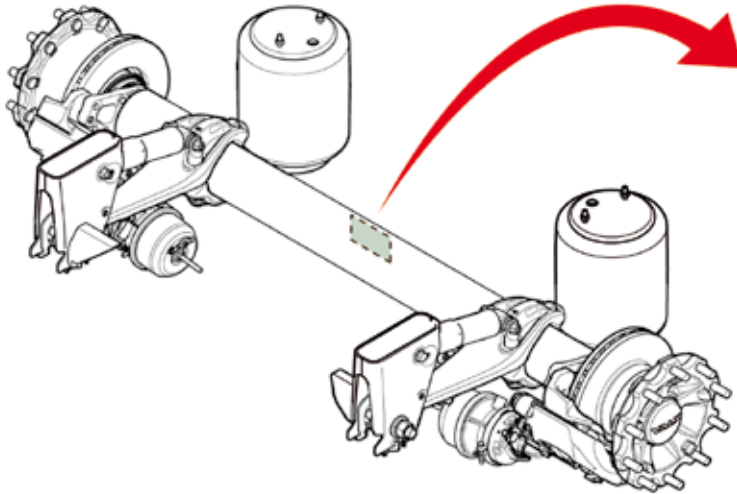

A: Axle type code

B: Brake approval (with test report number)

C: Permissible axle capacity static (in kg)

D: Axle number (barcode type 128)

E: Production number (barcode type 128)

F: Maximum allowable speed (in km/h)

G: Production number

H: Axle number – The axle number is built up as shown in the table on page 8.

2.2 Information on the identification plate

The identification plate consists of the following fields:

A: Axle type code – The axle type code is built up as shown in the table below.

	BRAKE TYPE	BRAKE DIAMETER	WHEEL	AXLE TYPE	LOAD CAPACITY (IN KG)		WHEEL BOLTS	
drum brake	D							
disk brake (rotor)	R							
small diameter (17.5" rim size)		S						
medium diameter (19.5" rim size)		M						
large diameter (22.5" rim size)		L						
single mounting / offset = 0			S					
double mounting			D					
single mounting / offset = 120			O					
no steering = rigid				X				
forced steering				F				
self steering				S				
energy				E				
heavy duty				H				
load capacity 9.000 kg					0	9		
load capacity 10.000 kg					1	0		
load capacity 11.000 kg					1	1		
load capacity 12.000 kg					1	2		
load capacity 13.000 kg					1	3		
hub with 6 wheel bolts							0	6
hub with 8 wheel bolts							0	8
hub with 10 wheel bolts							1	0

H: Axle number – The axle number is built up as shown in the table below.

	AXLE TYPE		AXLE SPECS				ID NUMBER	
	1	2	3	4	5	6	7	8
disk brake axle 17.5" rim size incl. ABS	1/9	4						
disk brake axle 17.5" rim size	1/9	5						
disk brake axle 19.5" rim size incl. ABS	1/9	6						
disk brake axle 19.5" rim size	1/9	7						
disk brake axle 22.5" rim size incl. ABS	1/9	8						
disk brake axle 22.5" rim size	1/9	9						
drum brake axle 17.5" rim size incl. ABS	2	4						
drum brake axle 17.5" rim size	2	5						
drum brake axle 19.5" rim size incl. ABS	2	6						
drum brake axle 19.5" rim size	2	7						
drum brake axle 22.5" rim size incl. ABS	2	8						
drum brake axle 22.5" rim size	2	9						
single mounting / offset = 0			0					
double mounting			1					
single mounting / offset = 120			2					

	AXLE TYPE			AXLE SPECS			ID NUMBER	
	1	2	3	4	5	6	7	8
no steering				0				
forced steering				1				
self steering				2				
energy				3				
heavy duty				4				
load capacity 9.000 kg					9			
load capacity 10.000 kg					0			
load capacity 11.000 kg					1			
load capacity 12.000 kg					2			
load capacity 13.000 kg					3			
hub with 6 wheel bolts						6		
hub with 8 wheel bolts						8		
hub with 10 wheel bolts						0		
unique ID number axles							0	1
							9	9

3. Maintenance chart

3.1 Disk brake axle

i NOTE | As road conditions may vary from one country to another, and specific use of the trailer axle may differ per haulier, the maintenance intervals given below are only indicative. The maintenance tables differentiate between on-road use (X) and off-road use (0).

INSPECTION ITEM	MAINTENANCE TASK	MAINTENANCE INTERVAL				
		EVERY 3 MONTHS	EVERY 6 MONTHS	EVERY YEAR	EVERY 3 YEARS	EVERY 5 YEARS
brake pad ¹	check the thickness of the friction material of the brake pad (minimum thickness: 2 mm)	0 / X				
brake disk	check for cracks, damage or wear (minimum thickness of the brake disk: 37 mm)	0	X			
	check the disk runout (maximum disk runout: 0.15 mm)		0	X		
brake cylinder ²	check the general condition of the brake cylinder (connection, damages, corrosion, leakage)	0	X			
adjuster	check the correct functioning (recommended clearance between brake pads and brake disk: between 0.7 and 1.1 mm)		0	X		
	check the presence of the adjuster sealing plug		0	X		
brake calliper ¹	manually check that the brake calliper slides correctly over the guide pins	0	X			
hold-down springs	check for cracks	0	X			
brake wear indicator (optional)	check the correct functioning		0 / X			

INSPECTION ITEM	MAINTENANCE TASK	MAINTENANCE INTERVAL				
		EVERY 3 MONTHS	EVERY 6 MONTHS	EVERY YEAR	EVERY 3 YEARS	EVERY 5 YEARS
all parts of the wheel hub unit	check for damage or wear	0	X			
tyres	check for damage or uneven wear	0 / X				
outer and inner bearing	check for play		0	X		
	replace grease and check bearings				0	X
seal	replace				0	X
wheel nuts ^③	check for correct fastening		0	X		

^① Always check the condition of the protection caps of both guide pins and the adjuster. Always check the play from the calliper on the guide pins when the brake pads have been removed.

^② Always check that the draining plug(s) at the bottom of the brake cylinder have been removed.

^③ Always check the correct fastening of the wheel nuts after the first journey with a loaded trailer and whenever the wheel in question has been replaced.

3.2 Drum brake axle

i NOTE | As road conditions may vary from one country to another, and specific use of the trailer axle may differ per haulier, the maintenance intervals given below are only indicative. The maintenance tables differentiate between on-road use (X) and off-road use (0).

INSPECTION ITEM	MAINTENANCE TASK	MAINTENANCE INTERVAL				
		EVERY 3 MONTHS	EVERY 6 MONTHS	EVERY YEAR	EVERY 3 YEARS	EVERY 5 YEARS
brake lining	check the thickness of the brake lining through the hole in the dust cover (minimum thickness: 5 mm)	0 / X				
brake drum	check for cracks, damage or wear	0	X			
	check the internal diameter of the brake drum when replacing the brake shoes					
brake cylinder ¹	check the general condition of the brake cylinder (connection, damages, corrosion, leakage)	0	X			
slack adjuster	check the correct functioning	0	X			
	lubricate the slack adjuster (2 grease nipples per axle)	0	X			
S-cam bearing	lubricate the S-cam bearing (4 grease nipples per axle)	0	X			

¹ Always check that the draining plug(s) at the bottom of the brake cylinder have been removed.

INSPECTION ITEM	MAINTENANCE TASK	MAINTENANCE INTERVAL				
		EVERY 3 MONTHS	EVERY 6 MONTHS	EVERY YEAR	EVERY 3 YEARS	EVERY 5 YEARS
all parts of the wheel hub unit	check for damage or wear	0	X			
tyres	check for damage or uneven wear	0 / X				
outer and inner bearing	check for play		0	X		
	replace grease and check bearings				0	X
seal	replace				0	X
wheel nuts [Ⓜ]	check for correct fastening		0	X		

[Ⓜ] Always check the correct fastening of the wheel nuts after the first journey with a loaded trailer and whenever the wheel in question has been replaced.

3.3 Air suspension

i NOTE | As road conditions may vary from one country to another, and specific use of the trailer axle may differ per haulier, the maintenance intervals given below are only indicative. The maintenance tables differentiate between on-road use (X) and off-road use (0).

INSPECTION ITEM	MAINTENANCE TASK	MAINTENANCE INTERVAL				
		EVERY 3 MONTHS	EVERY 6 MONTHS	EVERY YEAR	EVERY 3 YEARS	EVERY 5 YEARS
all parts of the air suspension system	all bolted connections are maintenance free in on-road conditions, but should be checked for rust-traces and movement regularly.		0	X		
	cracks in the paint of bolt connections are a sign of movement. Service technicians must check these bolt connections and, if necessary, retighten using the stated torques.		0	X		
air springs	check for damage, wear or incorrect seating		0	X		
	check correct fastening (see section 4.3 for recommended torque)		0	X		
shock absorbers	check for leakage (light oil sweating is allowed)		0	X		
air valves	check general condition		0	X		
axle clamping nuts	check correct fastening (see section 4.3 for recommended torque)		0			X
pivot bolt	check correct fastening (see section 4.3 for recommended torque)		0			X
axle beam	check for irregularities	0	X			
	check for damage, wear or corrosion	0	X			

4. Tightening torques

4.1 Tightening torques disk brake axle

i **NOTE** | Always tighten or check the fasteners with a calibrated torque wrench.

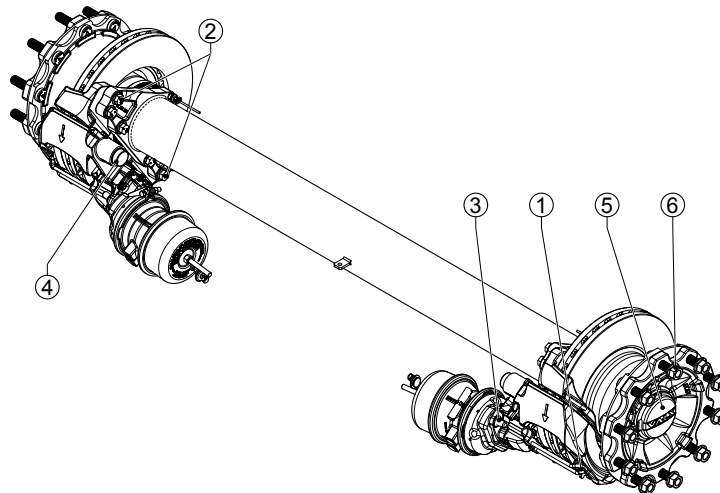

SUBASSEMBLY	ITEM	SIZE	WIDTH ACROSS FLATS	INSPECTION	WHEN REPLACING
brake system disk	1. hexagon bolt	M10	17	30 Nm	30 Nm (+15)
	2. flange bolts and flange shoulder bolt	M16 x 1.5	24	250 Nm	290 Nm (± 20)
	3. brake cylinder nuts	M16 x 1.5	24	175 Nm	210 Nm (-30) ¹
	4. internal hexagon bolts	M12	14	275 Nm	310 Nm (± 30)
wheel hub unit	5. axle nut	M55 x 1.5	75	not applicable	630 Nm (± 30)
	6. wheel nuts	M22 x 1.5	32	600 Nm	630 Nm (± 30)

¹ The torque refers to WABCO brake cylinders. If other brake cylinders are used, the brake cylinder nuts must be tightened to the torque specified by the supplier.

4.2 Tightening torques drum brake axle

i NOTE | Always tighten or check the fasteners with a calibrated torque wrench.

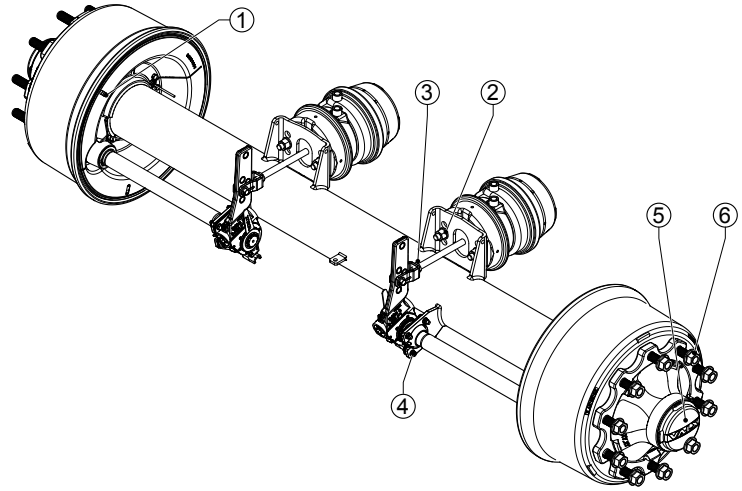

SUBASSEMBLY	ITEM	SIZE	WIDTH ACROSS FLATS	INSPECTION	WHEN REPLACING
brake system drum	1. dust cover bolts	M8	13	20 Nm	22 Nm (±4)
	2. brake cylinder nuts	M16 x 1,5	24	175 Nm	210 Nm (-30) ¹
	3. set nut yoke	M16 x 1,5	24	60 Nm	65 Nm (±4) ¹
	4. ball bearing nuts	M8	13	20 Nm	22 Nm (±4)
wheel hub unit	5. axle nut	M55 x 1.5	75	not applicable	630 Nm (±30)
	6. wheel nuts	M22 x 1.5	32	600 Nm	630 Nm (±30)

¹ The torque refers to WABCO brake cylinders. If other brake cylinders are used, the brake cylinder nuts must be tightened to the torque specified by the supplier.

4.3.1 Tightening torques air suspension

i NOTE | Always tighten or check the fasteners with a calibrated torque wrench.

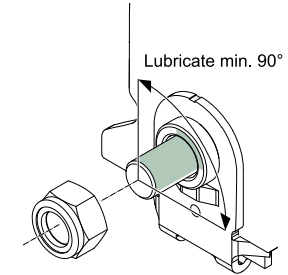
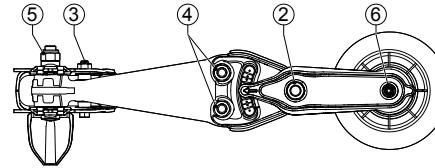
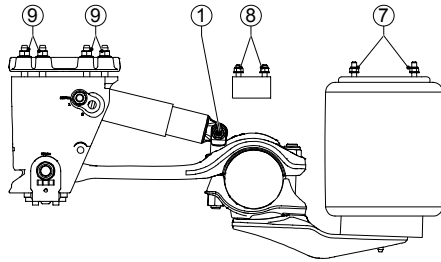

SUBASSEMBLY	SIZE	WIDTH ACROSS FLATS	INSPECTION	WHEN REPLACING
1. shock absorber (bottom)	M16	24	350 Nm	170 Nm (+17/-0) + 270° (+27/-13) ^③
2. a. axle clamp (rear)	M27	41	750 Nm	750 Nm (+50/-0) + max 180° ^{②④}
b. axle clamp (rear)	M27	41	750 Nm	950 Nm (+50/-0) ^④
3. shock absorber (top)	M20	24 & 30	550 Nm	550 Nm (+50/-0) ^③
4. axle clamp (front)	M24	36	650 Nm	800 Nm (+50/-0) ^④
5. a. pivot bolt	M27	41	1000 Nm	250 Nm (+25/-0) + 250° (+27/-13) + apply grease on min. 90° of the thread surface + ring ^{①②③}
b. pivot bolt	M27	41	1000 Nm	950 Nm (+50/-0) + apply grease on min. 90° of the thread surface + ring ^{①③⑤}
6. air spring (bottom)	M12	19	65 Nm	65 Nm (+10/-0)
7. air spring (top)	M12	19	30 Nm	30 Nm (+10/-0)
8. a. plastic bump fastening	M12	19	30 Nm	30 Nm (+10/-0)
b. steel bump fastening	M12	19	40 Nm	66 Nm (+0/-16)
9. bolted bracket	M16	24	300 Nm	170 Nm (+17/-0) + 270° (+17/-13)

^① Grease specification: Lithium complex grease (class 2) / ^② Preferred method / ^③ Torque at ride height / ^④ First tighten the M24 connection of the axle clamping, then tighten the M27 connection / ^⑤ For service purposes with manual torque wrench only

4.3.2 Tightening torques air suspension V2

i NOTE | Always tighten or check the fasteners with a calibrated torque wrench.

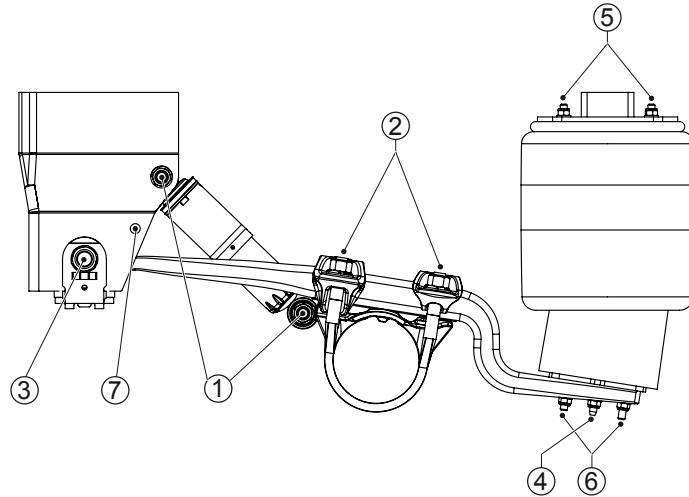

SUBASSEMBLY	SIZE	WIDTH ACROSS FLATS	INSPECTION	WHEN REPLACING
1. shock absorber (top + bottom)	M20	24 & 30	550 Nm	200 Nm (+20/-0) + 180° (+18°/-9°) [Ⓢ]
2. axle clamp	M22	32	600 Nm	600 Nm (+25/-0)
3. a. pivot bolt	M27	41	1000 Nm	250 Nm (+25/-0) + 250° (+27°/-13°) + apply grease on 1/4 of thread surface ^{1ⓈⓈ}
3. b. pivot bolt	M27	41	1000 Nm	950 Nm (+25/-0) + apply grease on 1/4 of thread surface ^{1Ⓢ4}
4. air spring (bottom)	M12	19	65 Nm	65 Nm (+10/-0)
5. air spring (top)	M12	19	30 Nm	30 Nm (+10/-0)
6. air spring support plate	M12	19	65 Nm	65 Nm (+10/-0)
7. axle lift	M16	24	200 Nm	200 Nm (+/-20)

[Ⓢ] Grease specification: Lithium complex grease (class 2) / [Ⓢ] Preferred method / [Ⓢ] Torque at ride height / [Ⓢ] For service purposes with manual torque wrench only

4.3.3 Tightening torques HD air suspension

i NOTE | Always tighten or check the fasteners with a calibrated torque wrench.

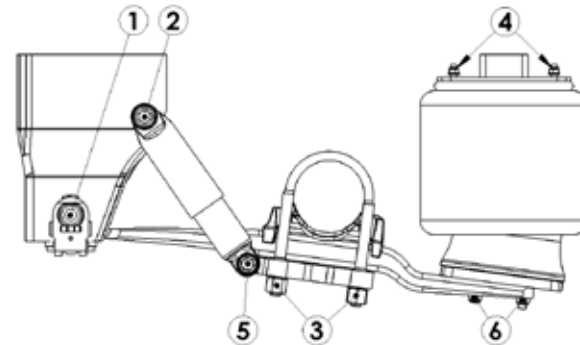
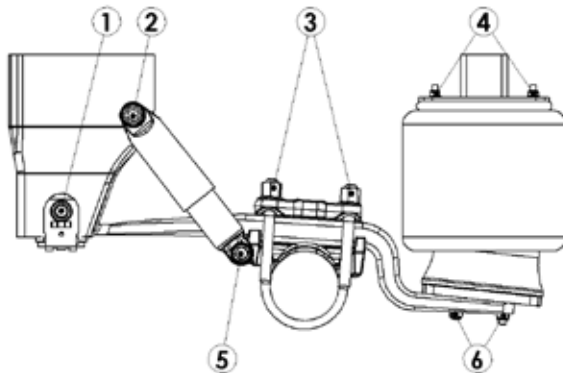
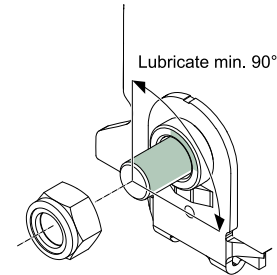

SUBASSEMBLY	SIZE	WIDTH ACROSS FLATS	INSPECTION	WHEN REPLACING
1. pivot bolt	M27	41	1000 Nm	250 Nm (+25/-0) + 270° (+27/-13) + apply grease on min. 90° of the thread surface + ring ¹
2. shock absorber (top)	M20	24 & 30	550 Nm	200 Nm (+20/-0) + 180° (+18/-9)
3. axle clamp	M24	36	800 Nm	800 Nm (+50/-0)
4. air spring (top)	M12	19	30 Nm	30 Nm (+10/-0)
5. shock absorber (bottom)	M20	24 & 30	550 Nm	200 Nm (+20/-0) + 180° (+18/-9)
6. air spring (bottom)	M16	24	200 Nm	200 Nm (+20/-20)

¹ Grease specification: Lithium complex grease (class 2)

5. Damaged tyre replacement

5.1 Preparatory actions

Place the wheel chocks

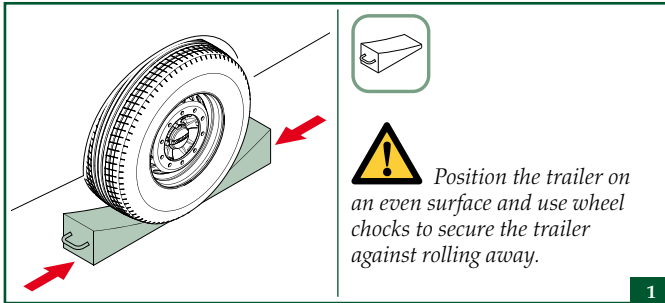

Jack up the trailer

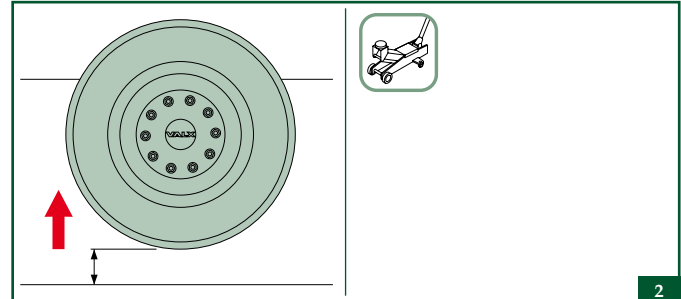
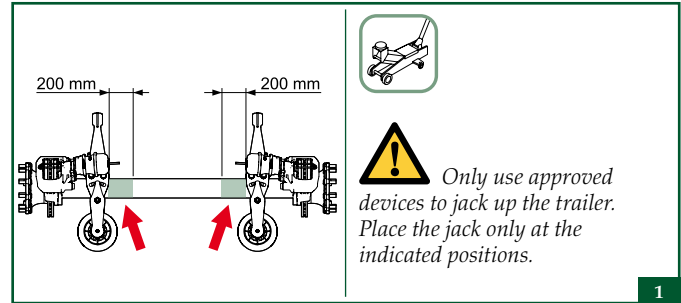

5.2 Remove the wheel(s)

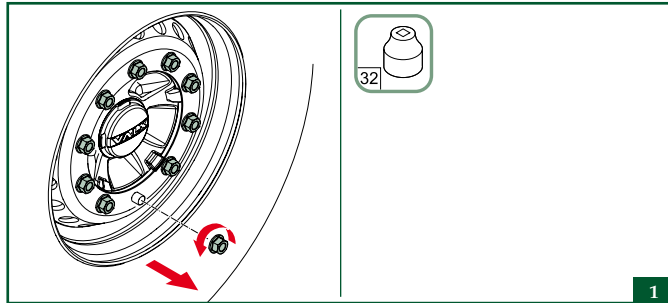

5.3 Install the wheel(s)

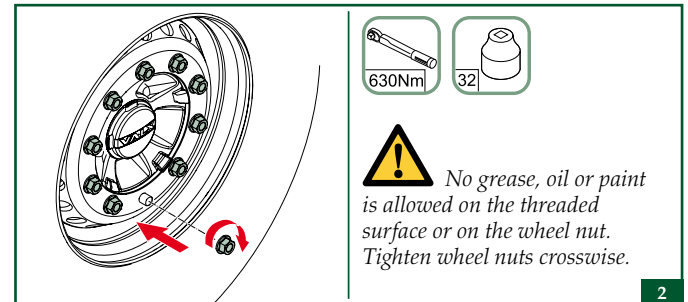
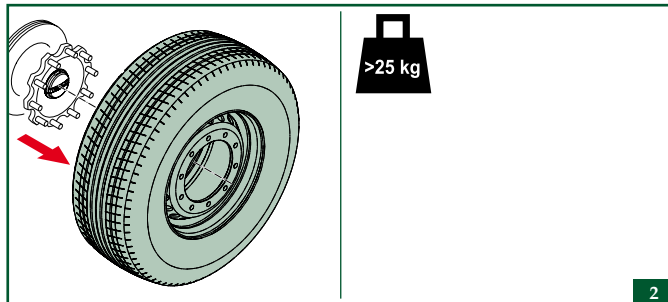
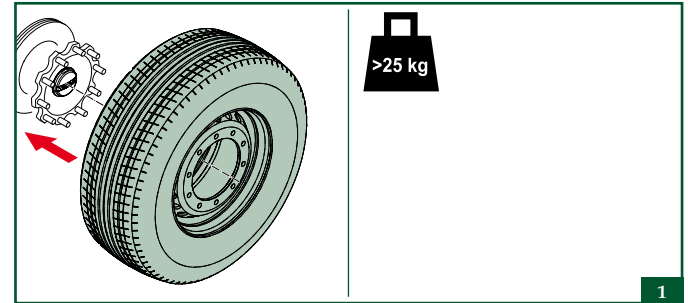

! No grease, oil or paint is allowed on the threaded surface or on the wheel nut. Tighten wheel nuts crosswise.

Torque

ITEM	SIZE	WIDTH ACROSS FLATS	INSPECTION	WHEN REPLACING
wheel nuts	M22 x 1.5	32	600 Nm	630 Nm (±30)

6. Hub cap

6.1 Removing the hub cap

Hub offset 120

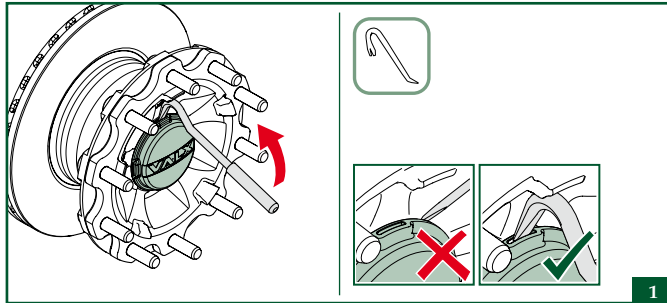

Hub offset 0

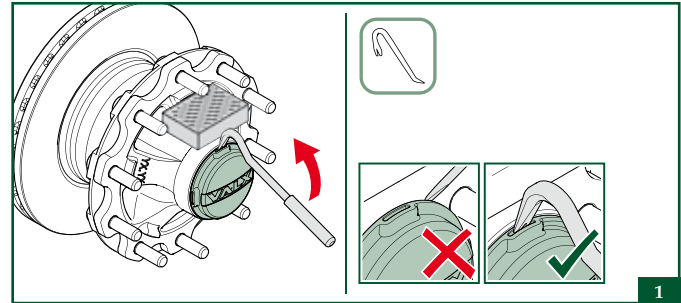

HD hub cap

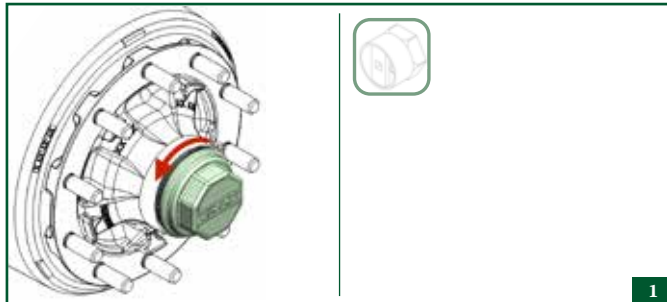

6.2 Mounting the hub cap

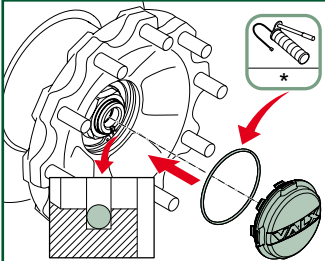

The diagram shows a cross-section of a hub assembly with a hub cap being placed on top. A red arrow points to the O-ring on the hub cap. A small inset shows a screwdriver with an asterisk next to it, indicating a warning.

*** Lithium complex grease (class 2)**

! Always replace the O-ring whenever the hub cap has been removed.

! Always check whether the O-ring is properly seated and not damaged.

1

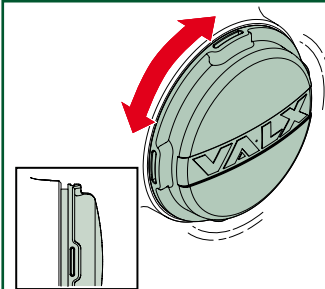

The diagram shows the hub cap being rotated around its axis, indicated by a red curved arrow. A small inset shows the hub cap being rotated. A warning icon is present.

! Make sure the hub cap can be rotated freely to ensure the O-ring is seated properly before step 3.

2

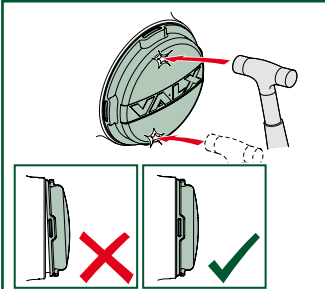

The diagram shows a hammer being used to tap the hub cap into place. A warning icon is present. Below the main diagram are two smaller diagrams: one showing a gap between the hub cap and the hub flange with a red 'X', and another showing the hub cap fully seated with a green checkmark.

! Make sure there is no gap between the edge of the hub cap and the hub flange, and check that the hub cap cannot be rotated by hand when fitted.

3

HD hub cap

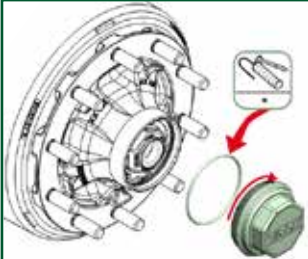

The diagram shows a hub cap being attached to a hub. A red arrow points from the hub cap towards the hub. A small inset shows a screwdriver being used to adjust a component. To the right, there are two icons: a torque wrench icon with '100Nm' and a warning icon showing a triangle with an exclamation mark and a curved arrow.

Always replace the O-ring whenever the hub cap has been removed.

Always check whether the O-ring is properly seated and not damaged.

* Lithium complex grease (class 2)

1

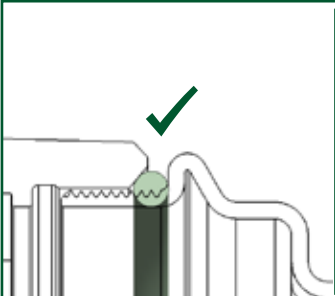

The diagram shows a cross-section of the hub cap assembly. A green checkmark is placed above the O-ring, indicating it is properly seated. To the right, there is a warning icon showing a triangle with an exclamation mark and a curved arrow.

2

7. Brake wear inspection

7.1 Disk brake axle

Check the thickness of the friction material of the brake pad

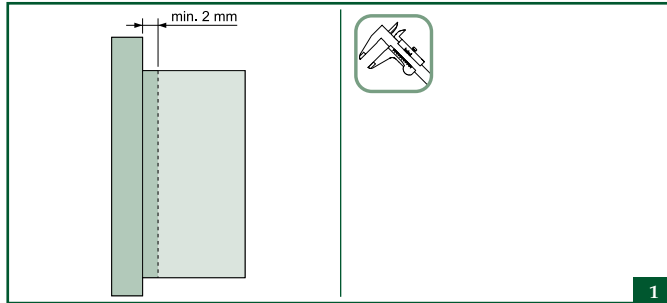

Check the condition of the brake disk

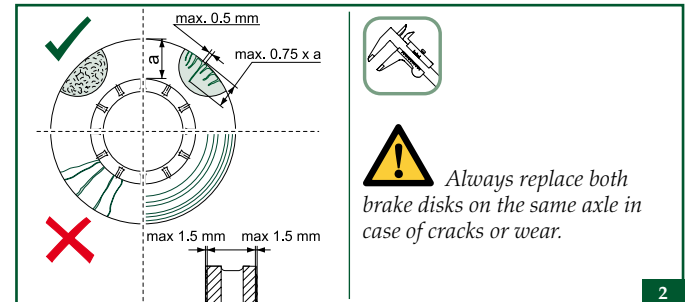
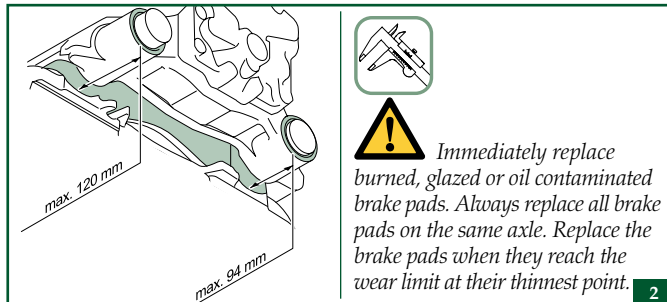
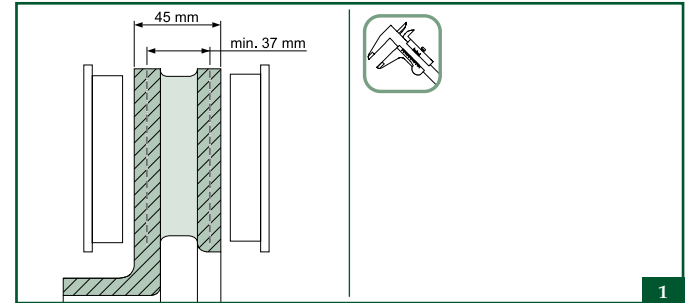

7.2 Drum brake axle

Check the thickness of the brake lining

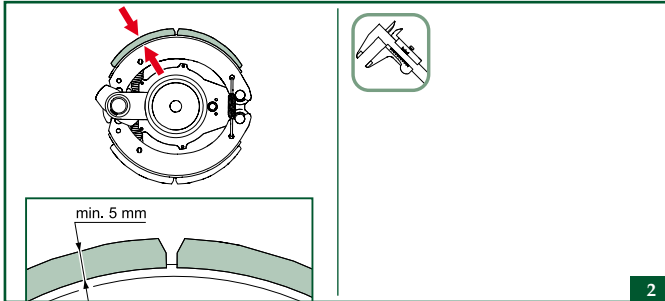
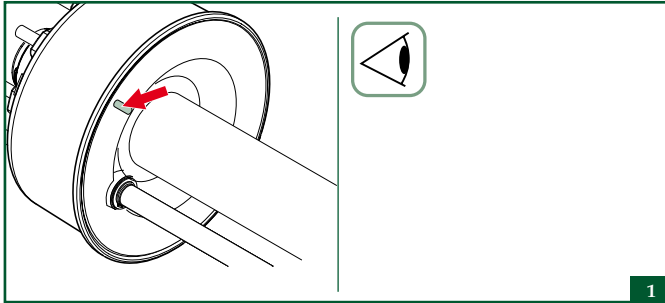

Check the internal diameter of the brake drum

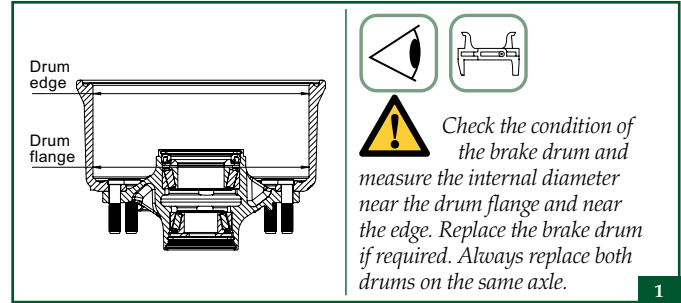

BRAKE	BRAKE SHOE WIDTH (MM)	Ø MAX. WEAR	MAX. MACHINED Ø (MM)
DR 420 x 180	178	425	424
DR 360 x 200	200	364	363

8. 24/7 Breakdown support

Fast, effective service is key in transport and trailer business. An effective support network for regular maintenance, spare parts and emergency response must be available throughout Europe. We've taken care of that. VALX, with both existing and new partners, provides the support you need, when and where you need it.

VALX has ensured that adequate sales & service facilities are in place on a Europe-wide basis. That means VALX axle users can count on fast and effective local service anywhere in Europe. This support makes sure that in case of any problems, trailers are back on the road in the shortest possible time.

To support operators with urgent service requirements, the international multi-language emergency support help-line can be reached 24 hours per day on **+31 (0)88 405 8899**.



Service & Spare Parts are available through the existing VALX service & support network of around 350 trailer partner repair shops and 450 spare parts dealers across Europe. To find the names and addresses of all VALX' Service and Spare Parts Dealers, visit **www.valx.eu** or call VALX (+31 (0)88 405 8800).

Notes:

.....

.....

.....

.....

.....

.....

.....

.....

.....

.....

.....

.....

.....

.....

.....

.....

.....

.....

.....

.....

Although the content of this document has been created with utmost thorough attention, VALX bv is not responsible for faults in this document resulting in damage or costs. The content of this manual cannot be reproduced or distributed in any form without written permission of the owner, VALX bv.



VALX bv

De Amert 700 C
NL-5462 GH Veghel
The Netherlands

phone +31 (0)88 405 8800

fax +31 (0)88 405 8820

email info@valx.eu

web www.valx.eu

technical support

email support@valx.eu

sales support

email sales@valx.eu

Valx axles. The smart alternative.

